



Fueling and Servicing Procedures Manual

TITLE PAGE

Original Issue – 15 Apr 14

Revision 35 – 07 Apr 20



Commitment to Safety and Security

Safety and security are core values at Envoy. They are our highest priorities for our passengers, employees and aircraft and are imbedded into the culture of our airline. Running a safe and secure operation is the key to our success and every day we work to be best at doing so. To reach this goal, we rely on our safety management system (SMS) and the sound judgement and experience of our employees. Safety must be the first and foremost consideration in every decision and in every facet of our Company and operation.

Envoy constantly develops, implements, maintains our safety and security policies, processes and systems so we continually improve and achieve the highest levels of performance. We will meet this commitment by ensuring sufficient resources are available to develop, implement, maintain, and continually improve our level of safety and security through our safety management system.

We have established and operate hazard identification and risk management processes, including a confidential reporting system, to eliminate or mitigate the likelihood and consequences of operational hazards.

To comply with all applicable regulatory requirements and standards, Envoy has implemented numerous confidential safety reporting programs. We encourage employees to use these programs such as our Aviation Safety Action Programs (ASAP), Confidential Safety Action Program (CSAP), Safety Hotline **800-477-3002**, or email envoy.safety@aa.com to report safety or security concerns. We encourage you to use these reporting programs to notify Envoy of your concern, and what has led you to believe this to be a concern. No disciplinary action will be taken unless, after thorough review of an incident, it is found that unacceptable behavior exists such as criminal activity, substance abuse, reckless behavior, willful disregard of regulations or procedures, repetitive behavior or knowingly providing false information. Neither the written Safety Report, nor information called into the Safety Hotline of an accepted report will be used to initiate or support Company disciplinary action, or the PPC process. Envoy retains its discretionary authority to take disciplinary action on events not meeting acceptance criteria.

The President and CEO, as the accountable executive, has made the following assignments regarding the accountability and responsibilities of management and employees with respect to safety performance by making:

- Each Officer accountable for the overall safety performance of their department and employees. Each Officer is accountable to develop, implement, and maintain the SMS, Security process and emergency response plan within their area of responsibility.
- Each department responsible for providing policies, procedures, and training to prevent accidents and injuries and for ensuring responsiveness to employee issues
- Each employee group identify, define, and promote safe operating practices
- Each manager accountable for delivering safety and compliance performance within their teams
- Each employee responsible for complying with all safety policies and procedures to ensure his or her safety, and the safety of coworkers and our customers, as well as immediately and accurately reporting safety issues to their supervisor

The Safety Department's role is to assist all employees in preventing accidents, injuries, damage to aircraft, and unlawful interference with airline operations. This team is dedicated to facilitating Envoy's safety and security policies, processes and systems using best-in-class principles and quality measurement processes. Envoy also provides for the safe transition from normal to emergency operations in accordance with our Corporate Emergency Response Plan.

Safety objectives are formulated and produced in a report on an annual basis. They will be measured quarterly to identify adverse trends to correct potential issues thru the continual improvement process of our Safety Management System and Security Management System. Envoy is committed to fulfill the safety objectives, report results to leadership on an annual basis and to ensure a safe working environment in order to protect our people, passengers and aircraft.

Envoy's goal is to be the best in our industry. This can only be done by us running a safe, reliable and secure operation. Every employee is responsible for doing their part to ensuring this happens. Thank you for the all of the hard work and dedication to your colleagues, passengers and our Company to help us reach this goal.

A copy of this commitment, bearing the signatures of Senior Management, is available at:

<https://my.envoyair.com/index.php/policies/business-ethics/envoys-commitment-to-safety-and-security/>

Fueling and Servicing Procedures Manual

RECORD OF REVISIONS

Rev. No.	Effective Date	Rev. No.	Effective Date	Rev. No.	Effective Date
00	15 Apr 14	29	07 May 19	58	
01	06 May 14	30	06 Aug 19	59	
02	03 Jun 14	31	03 Sep 19	60	
03	05 Aug 14	32	01 Oct 19	61	
04	02 Sep 14	33	05 Nov 19	62	
05	07 Jan 15	34	04 Feb 20	63	
06	03 Feb 15	35	07 Apr 20	64	
07	03 Mar 15	36		65	
08	07 Apr 15	37		66	
09	05 May 15	38		67	
10	02 Jun 15	39		68	
11	01 Sep 15	40		69	
12	01 Dec 15	41		70	
13	01 Mar 16	42		71	
14	02 Aug 16	43		72	
15	07 Feb 17	44		73	
16	07 Mar 17	45		74	
17	04 Apr 17	46		75	
18	02 May 17	47		76	
19	01 Aug 17	48		77	
20	07 Nov 17	49		78	
21	05 Dec 17	50		79	
22	05 Jun 18	51		80	
23	07 Aug 18	52		81	
24	02 Oct 18	53		82	
25	06 Nov 18	54		83	
26	04 Dec 18	55		84	
27	05 Feb 19	56		85	
28	02 Apr 19	57		86	

REVISION 35 HIGHLIGHTS

Summary of Changes

1. Contact Technical Publications if there is an error displaying this publication.
2. Forms added, revised or removed in this revision are as follows:
 - a) AE-FSPM-0200 Fuel Vendor Training Record (Revised)
 - b) AE-FSPM-0200.1 Designated Trainer Authorization (Revised)

#	SECTION	SECTION TITLE	HIGHLIGHTS
1.	00-02	Interface List	Remove outdated CRJ references.
2.	02-00	Personnel Qualifications	Remove outdated CRJ references, update forms AE-FSPM-0200, AE-FSPM0200.1.
3.	05-01	CRJ-700 Fuel Servicing	Remove section.
4.	06-01	Forms Index	Remove outdated CRJ references.

NOTE

Change bars in the left margin indicate revision or deletion of content.

Refer to [Revision Status](#) located on the Technical Publications website for manual revision status.

END

Fueling and Servicing Procedures Manual

TOC/LEP
Page 1 of 2
07 Apr 20

TABLE OF CONTENTS/LIST OF EFFECTIVE PAGES

SUBJECT	Chapter/ Section	Page Count	Rev Date
FRONT MATTER			
Title Page/Safety Letter		1/2	07 Apr 20
Record of Revisions		1	07 Apr 20
Revision Highlights		1	07 Apr 20
Record of Temporary Revisions		1	07 Apr 20
Table of Contents/List of Effective Pages		1/2	07 Apr 20
INDEX/GLOSSARY			
Definitions and Terms	00-00	1 - 3	04 Dec 18
Acronyms	00-01	1/2	07 May 19
Interface List	00-02	1	07 Apr 20
MANUALS			
Manual System and Structure	01-00	1/2	04 Feb 20
Standards for Fuel Providers	01-01	1	07 Jan 15
Removed	01-02		
Removed	01-03		
GENERAL			
Personnel Qualifications	02-00	1 - 4	07 Apr 20
Alternate Procedures	02-01	1 - 3	05 May 15
Fuel Properties and Safety Practices	02-02	1 - 5	07 May 19
Fuel Servicing Vehicles	02-03	1/2	06 Aug 19
Grounding and Bonding	02-04	1	01 Aug 17
General Fueling Procedures	02-05	1 - 3	01 Oct 19
Non-Listed Fueling Procedures	02-06	1 - 4	05 Nov 19
Fuel Service Provider – Into-Plane and Storage	02-07	1 - 4	05 Feb 19
FUEL QUALITY CONTROL STANDARDS			
Fuel Quality Control Standards	03-00	1 - 3	07 Jan 15
Product Standards for Jet Fuel Received, Stored and Dispensed to the Company	03-01	1/2	02 Sep 14
Fuel Acceptance by Pipeline and Marine Vessels	03-02	1 - 4	15 Apr 14
Fuel Acceptance by Transport Truck and Rail Car	03-03	1 - 4	15 Apr 14
Fuel Storage Facility Requirements	03-04	1/2	15 Apr 14
Fuel Storage Facility Inspections	03-05	1 - 12	15 Apr 14

Fueling and Servicing Procedures Manual

TOC/LEP
Page 2 of 2
07 Apr 20

Fueling Vehicle Requirements	03-06	1/2	15 Apr 14
Fueling Vehicle Inspections	03-07	1 - 10	02 Apr 19
Hydrant System Checks	03-08	1 - 7	02 Apr 19
Clear and Bright Test	03-09	1/2	15 Apr 14
White Bucket Test	03-10	1 - 3	15 Apr 14
Membrane Filtration Test	03-11	1/2	01 Mar 16
Free Water Test	03-12	1/2	15 Apr 14
API Gravity Test	03-13	1 - 4	15 Apr 14
Filter Vessel Differential Pressure	03-14	1 - 3	07 Feb 17
Bonding Cable Continuity Check	03-15	1/2	15 Apr 14
Water Defense System (Automatic Water Slug and Dump Systems)	03-16	1/2	15 Apr 14
Fuel Storage Tank Inspection and Cleaning	03-17	1/2	15 Apr 14
Water Separator Test (Microsep)	03-18	1	15 Apr 14
Filter Element Replacement Criteria	03-19	1	15 Apr 14
Hydrant Systems Cleaning Standards – Fuel System Piping	03-20	1/2	15 Apr 14
Fuel Truck Tank Cleaning	03-21	1	15 Apr 14
FUELING SELF-AUDIT			
Fueling Self-Audit Procedures	04-00	1 - 3	05 Nov 19
Removed	04-01		
Removed	04-02		
FUELING INSTRUCTIONS			
EMB 145 Fuel Servicing	05-00	1 - 8	03 Sep 19
Removed	05-01		
ERJ-175 Fuel Servicing	05-03	1 - 11	03 Sep 19
FORMS			
Forms	06-00	1	07 Feb 17
Forms Index	06-01	1/2	07 Apr 20

END

DEFINITIONS AND TERMS

CONTENTS

00-00.A	General	1
00-00.B	Responsibility and Authority	1
00-00.C	Definitions and Terms	1

A. GENERAL

1. The following definitions and terms apply to this manual.
2. The material in this section interfaces with GPM 00-01 and MTPM 06-00.

B. RESPONSIBILITY AND AUTHORITY

1. The Director Maintenance Safety and Compliance (DMSC) is the Person with Primary Responsibility (PPR) for this manual with authority for changes thereof.

C. DEFINITIONS AND TERMS

1. ACCEPTED: Describes a document, program, manual, a section of a manual, or a checklist that does not have, or is not required to have, FAA approval.
2. ACCIDENT, AIRCRAFT: An occurrence associated with the operation of an aircraft, which takes place between the time any person boards the aircraft with the intention of flight, until such time as all such persons have disembarked, and in which any person suffers death or serious injury, or in which the aircraft receives substantial damage.
3. ADMINISTRATOR: The Federal Aviation Administrator or any person to whom he has delegated his authority in the matter concerned.
4. AIRCRAFT MAINTENANCE MANUAL: Inclusive of the appropriate engine and component maintenance manuals, etc.
5. API DEGREES: Are units for fuel density measurement.
6. API GRAVITY: A specific test method for determining the density of fuel.
7. APPLICABLE: Capable or suitable for being applied.
8. APPROPRIATE: Especially suitable or compatible; fitting.
9. APPROVED: Describes a program, manual, a section of a manual, or a checklist, requiring FAA regulation to evaluate and specifically approve any changes made prior to implementation (unless an exception has been granted by the FAA).
10. AUTO-IGNITION TEMPERATURE: Minimum temperature required in a substance to initiate or cause self-sustaining combustion independently of any sparks or other means of ignition.
11. AVAILABLE: Accessible, obtainable.
12. CALIBRATION: Making precise measurements and adjustments to equipment or systems in order to obtain optimum performance and to certify that output data falls within prescribed tolerances.
13. CERTIFICATION: Written testimony of qualification (e.g., licenses, certifications, etc.).
14. CERTIFYING AGENCY: The employer of the personnel being certified.
15. CERTIFYING AUTHORITY: The person or persons properly designated in the written practice to sign certificates on behalf of the employer.
16. CHECK: The procedures necessary to determine the condition of a component or system by physical movement, measurement, operation or examination.
17. CLAY TREATMENT VESSEL: A vessel equipped with bulk clay, clay bags or clay canisters used for removing surface-active-agents (surfactants) from fuel.
18. CLEAR-AND-BRIGHT TEST: Means that, when visually examined in a clear glass container, the product is visually free from undissolved water, sediment and suspended matter. A product suitable free from these contaminants produces a bright sparkling appearance.
19. CLOSED RECLAIM SYSTEM: A system which allows collection and filtration of sump fuel without exposure of the fuel to contamination by other products.

20. **COALESCER ELEMENT:** A device which removes solid particles and coalesces free water from fuel and is the first stage cartridge in the filter/separator vessel. It is upstream of the separator cartridge.
21. **COMPANY:** Certificate holder, Envoy Air Inc. SIMA 586A.
22. **CONTAMINANTS:** Substances either foreign or native which may be present in jet fuel that detracts from its performance.
23. **DEADMAN CONTROL:** A control device which must be hand-held open by the operator. When released by the operator, flow stops.
24. **DIFFERENTIAL PRESSURE:** The difference in pressure readings (psi) taken on the inlet and outlet sides of a filter vessel. Also, referred to as Delta P or written as ΔP or ΔP .
25. **DIRECT READING DIFFERENTIAL PRESSURE GAUGE:** A pressure gauge which senses the pressure on the inlet and outlet sides of a filter vessel and automatically displays the differential pressure.
26. **DISTILLATION RANGE:** The overall volatility of a fuel through its entire distillation range is shown by its initial and final boiling points - a factor distinct from the flash point and vapor pressure.
27. **DOCUMENTED:** The condition of being in proper written form.
28. **ELECTROSTATIC SUSCEPTIBILITY:** The degree to which aviation fuels acquire and build up a static charge depends upon many factors, such as fuel type, amount and type of impurity, linear velocity in pipes, hoses and filters, type and condition of charge, separating surface, conductivity and treating reagents.
29. **EXPERIENCE:** Work activities accomplished in a specific method and related activities, but not including time spent in organized training programs.
30. **FILTER ELEMENTS:** Generic term given to various decontaminate media installed in various types of pressure vessels, e.g., coalescer elements, separator elements, clay bags, clay canisters and micronic elements.
31. **FILTER/SEPARATOR:** A filter vessel which removes solids, and coalesces and separates suspended free water from fuel. All filter/separators are equipped with two types of elements: coalescer elements (first stage) and separator elements (second stage).
32. **FATAL INJURY:** Any injury which results in death within 30 calendar days of the accident.
33. **FLASH POINT:** The lowest fuel temperature at which ignition can occur. The minimum flash point of Jet A and Jet A-1 38°C (100°F) is usually above the normal fuel handling temperatures and sea level pressures experienced. However, where the possibility exists that Jet A or Jet A-1 may be heated to or above its flash point, there is danger that the resulting vapors can form ignitable mixtures. This condition may develop within a tank truck which is parked in the sun for extended periods or where ambient temperatures remain in the 38°C (100°F) range or above for extended periods.
34. **GRANDFATHERED:** Certification of individuals that are considered qualified or meet the equivalent qualifications of the current system under a prior qualification program.
35. **INCIDENT:** An occurrence, other than an accident, associated with the operation of an aircraft, which affects or could affect the safety of operations.
36. **INSTRUCTOR:** Individual who provides classroom and on the job training in the method which they are certified/qualified.
37. **MAINTENANCE:** Actions required for restoring or maintaining an item in serviceable condition, including servicing, repair, modification, overhaul, inspection and determination of condition.
38. **MANAGEMENT:** Any person in a position that supervises personnel or is in charge of a particular project, or is designated as the person in charge during his period of duty. Includes crew chief, supervisor, manager, director, etc.
39. **ON THE JOB TRAINING (OJT):** Training, during work time, in learning instrumentation set up, equipment operation, recognition of indications, and interpretation under the technical guidance of an experienced Level II, Level III or other qualified designated individual.
40. **ORGANIZED TRAINING PROGRAM:** Formal training, in classroom situations, where the intended purpose is qualification, certification or re-certification in a specific NDT method.
41. **PARTICULATES:** Solid contaminants found in jet fuel, (e.g. dirt, rust, sand, fibers).
42. **PARTICULATE (MICRONIC) FILTER VESSEL:** A vessel equipped with a pleated-type paper cartridge which removes solids.

-
43. PRE-CHECK VALVE: A device used to check the operation of the automatic high level shut-off on refueling tenders.
 44. PRODUCT: Unless the text indicates otherwise, it normally means jet fuel.
 45. POSITIVE SUMP: A chamber or depression installed at the bottom of a tank or filter vessel to facilitate the collection and removal of contaminants.
 46. PROFICIENCY: Maintaining the skill or ability in the method of which qualified.
 47. QUALIFICATION: Demonstrated skill, documented training, demonstrated knowledge, and experience required for personnel to properly perform the duties of a specific job.
 48. SEPARATOR ELEMENT: Allows passage of fuel, but repels free water droplets and is the second stage cartridge or shroud in a filter/separator vessel. It is downstream of the coalescer cartridge.
 49. SERIOUS INJURY: Any injury which requires hospitalization for more than 48 hours, commencing within seven days from the date the injury was received, results in a fracture of any bone (except simple fractures of fingers, toes, or nose), causes severe hemorrhages, nerve, muscle or tendon damage, involves any internal organ; or involves second or third degree burns, or any burns affecting more than five percent of the body surface.
 50. SIGN: Means initials or signature including legible employee number or stamp.
 51. STATION MANAGER/GENERAL MANAGER: Both are references to the Station General Manager.
 52. SUMP FUEL: Fuel removed from fixed facility tank and filter vessel sumps and mobile equipment sumps while performing routine quality assurance tests or maintenance on equipment.
 53. SURFACTANTS (Surface-active-agents): Detergent-like compounds frequently found in jet fuel. These compounds are of concern because they have a disarming effect on elements used in filter/separators. Clay treatment is one means used in removing surface-active-agents from jet fuel.
 54. SURGE TANKS: Tanks that collect the fuel from high-pressure relief valves on hydrant carts.
 55. THERMOHYDROMETER: A hydrometer with a built-in thermometer and is used to determine fuel density and temperature using one device.
 56. TRAINEE: An individual who is in the process of being qualified.
 57. TRAINER: An individual who provides classroom and on the job training.
 58. TRAINING: The program developed to impart the knowledge and skills necessary to qualify.
 59. VAPOR PRESSURE: Pressure exerted by a vapor when in equilibrium with its own liquid form. Vapor pressure is a function of the fuel composition and temperature. For aviation fuels, the vapor pressure is measured by the Reid or Micro Method at 38°C (100°F). (ASTM D-323, D-2551) Because of high vapor pressure of aviation gasoline, they give off flammable vapors in ignition amounts at normal temperatures and pressures.
 60. VENDOR: An organization or person who operates and maintains fixed fuel storage or delivery facilities, mobile refueling equipment, providing service to the Company.
 61. WASTE FUEL: Is generally contaminated fuel resulting from exposure to biological activity, surfactants, oil/water separators, chemicals, petroleum product mixes, surface drains and from various water and/or solid particle combinations.
 62. WATER DEFENSE SYSTEM: A device which senses a predetermined level of free water in filter/separator sumps, and automatically stops the flow of fuel to prevent downstream contamination.
 63. WORKING TANK: The fuel storage tank being used to supply fuel to fueling trucks or the Hydrant System.

END

ACRONYMS

AA	American Airlines
AC	Advisory Circular
ANNUC	Annunciator
AOM	Aircraft Operating Manual
API	American Petroleum Institute
ASTM	American Society of Testing and Materials
ATA	Air Transport Association of America
C	Celsius
CAPT	Captain
CHDO	Certificate Holding District Office
CPM	Company Produced Manual
CPMM	Company Produced Maintenance Manual
CPN	Company Part Number (AA)
DQC	Director Quality Control
EFS	Emergency Fuel Shut-off
EICAS	Engine Indicating Crew Alerting System
ESM	Engineering Specification Manual
F	Fahrenheit
FAA	Federal Aviation Administration
FBO	Fixed Base Operator
FO	First Officer
FSPM	Fueling and Servicing Procedures Manual
FWD	Forward
GAL	Gallon
GPM	General Procedures Manual
GPU	Ground Power Unit
H	High
IAW	In Accordance With
MAINT	Maintenance
MCM	Maintenance Check Manual
MOC	Maintenance Operations Control
MOCPM	Maintenance Operations Control/Planning Manual
MSC	Maintenance Safety and Compliance
MTX	Maintenance
NA	Not Applicable
NBS	National Bureau of Standards
NDT	Non-Destructive Testing
NFPA	National Fire Protection Agency
NTSB	National Transportation Safety Board
NU	Not Used
OEM	Original Equipment Manufacturer
OSHA	Occupational Safety and Health Administration
PIC	Pilot-in-Command
PRESS	Pressure
PSI	Pounds Per Square Inch
PSIA	Pounds Per Square Inch Absolute
PSIG	Pounds Per Square Inch Gauge
PWS	Potable Water System

Fueling and Servicing Procedures Manual

REC	Record
REV	Revision
ROR	Record of Revision
ROTR	Record of Temporary Revisions
RPM	Reliability Procedures Manual
SDS	Safety Data Sheet
SOC	System Operations Control
SOM	Station Operating Manual
SOV	Shut-Off Valve
STA	Station
TEMP	Temperature
TOC	Table of Contents
TR	Temporary Revision
VP	Vice President

END

INTERFACE LIST

CONTENTS

00-02.A	General	1
00-02.B	Department Interfaces	1

TABLES

Table FSPM 00-02.a	Fueling and Servicing Procedures Manual Interfaces to Other Manuals	1
--------------------	---	---

A. GENERAL

- The following table identifies Envoy's Fueling and Servicing Procedures Manual (FSPM) interfaces to other manuals, and it briefly describes the function. The table identifies:
 - Source Document/Section Title Columns
Provides reference to procedures or information related to tasks that vendor personnel use to service aircraft and which contain the specific requirements of the Subject/Task, but may not include all the procedures used by vendor personnel.
 - Interface Reference/Subject/Task Columns
Provides reference to and description of responsibilities, specific processes and procedures utilized by vendor personnel in accomplishing fuel servicing.
- Persons performing revisions to the procedures in this manual shall also ensure any applicable interfaces to the GPM and other manuals are identified and revised using the procedures in GPM 01-06 [Ref. GPM 01-06]

Table FSPM 0002.a: Fueling and Servicing Procedures Manual Interfaces to Other Manuals.

SOURCE DOCUMENT	SOURCE DOCUMENT SECTION TITLE	INTERFACE REFERENCE	SUBJECT / TASK
Embraer 140/145 AMM (Part II)	12-11-01 12-11-02	FSPM 05-00 FSPM 05-00	EMB-140/145 pressure and gravity fuel servicing.
ERJ-175 AMM (Part II)	12-10-28	FSPM 05-03	ERJ-175 pressure and gravity fuel servicing.
FSPM 02-06	Off Line Fueling Procedures	FM1 7-03.2	Provides guidance to flight crew for off line fuel quality inspections.
FSPM 02-06	Off Line Fueling Procedures	DPM 08-00 2.2	Provides guidance to Dispatcher and SOC MOD for off line fuel inspections.
FSPM 05-00(A)(3) 05-03(A)(3)	EMB Fuel Servicing ERJ-175 Fuel Servicing	FM1 7-03.1	Provides guidance for fueling with passengers on board aircraft.

B. DEPARTMENT INTERFACES

- The following departments may be impacted by changes to the Envoy FSPM:
 - AAG Fuel Purchasing
 - Envoy System Operations Control
 - Envoy Technical Publications
 - Envoy Flight Operations
- Prior to release of proposed changes to the manual, or changes that may impact Company operations, the above departments will be contacted with the details of changes. Proposed changes will be assessed for impact to the departments and adjustments to the manual will be made as required.

END

MANUAL SYSTEM AND STRUCTURE

CONTENTS

01-00.A	General	1
01-00.B	Manual Structure	1

A. GENERAL

1. Envoy Air Inc., has established a system of manuals in accordance with 14 CFR Part 121. This manual system is divided into four categories as follows [Ref. 14 CFR 121.135(b)]:
 - a) Operations
 - b) Maintenance
 - c) Field Services
 - d) Safety/Security
2. The Maintenance Manual complies with the provisions of 14 CFR 121.135, 121.367 and 121.369. The Maintenance Manual is divided into several separately tracked and controlled manuals, and it contains the technical information that sets forth the policies, specifications and procedures by which the Company's maintenance organization operates. If there is a conflict between the Maintenance Manual and a federal regulation, the regulation takes precedence [Ref. 14 CFR 121.135(b)(1), (b)(2), 121.367 and 121.369].
3. The Maintenance Manual must be maintained and current [Ref. 14 CFR 121.133].
4. The material in this section interfaces with GPM 01-00 and MTPM 06-00.
5. To provide information more efficiently to the field, manuals and work cards are published on the [Tech Pubs website](#). A list of data published is located on the home page of the website.
6. If technical data is not immediately available, refer to GPM 03-01, paragraph "Technical Data Published on Website."
7. Operations Specifications and regulatory references are incorporated into the manual. Requirements and/or excerpts are identified when used. Further information is available in MTPM 06-00.
8. The terms "Envoy Air Inc.", "Envoy", and "the Company" are used interchangeably throughout the context of the manuals.
9. All personnel are encouraged to provide feedback and suggestions on manual content and improvements. This manual is revised as follows:
 - a) Requests and recommendations for revisions, additions or deletions to the Fueling and Servicing Procedures Manual shall be submitted to the Director Maintenance Safety and Compliance (DMSC) for review and approval.
 - b) If approved, the DMSC shall enter the request into the RFS database.
 - c) The RFS will be processed in accordance with GPM 04-09 [Ref. GPM 04-09].

B. MANUAL STRUCTURE

1. Revision, Effective and Issue Dates
 - a) Revision dates are used by the writer and/or publisher of the data to establish a control date that ties to a particular revision number. Revision dates on title pages and manual pages do not always denote the effective date.
 - b) Effective dates are the dates any OEM or Company manual, revision or other technical data becomes operational and required for use. The effective date is determined by Technical Publications based on the distribution of required data. Effective dates are listed under Revision Status located on the [Tech Pubs website](#).
 - c) Issue dates may also be used by OEMs to establish a control date that ties to a particular revision number. These dates do not always denote the effective date. Issue dates do not apply to Company-produced manuals (CPMs).
2. Manual currency may be verified by using the TOC/LEP pages.
3. Directive information is regulatory in nature and uses terms such as "shall" and "must". These terms mean that the actions are **mandatory**. "Shall not" and "must not" mean that the actions are **prohibited**.
4. "May" is used in a permissive sense to state authority or permission to do the act prescribed, and the words "no person may" or "a person may not" mean that no person is required, authorized or permitted to do the act prescribed.

5. Guidance information is considered guiding in nature and will contain terms such as “will”, “should” or “may”. These terms indicate actions that are desirable, permissive or not mandatory and allow flexibility.
6. “Includes” means “includes but is not limited to.”
7. Words imparting the:
 - a) Singular include the plural (e.g., person includes personnel) and vice versa.
 - b) Masculine gender include the feminine (e.g., his includes hers) and vice versa.
8. Management title is inclusive of that person’s designee/delegate. Delegation of duties is permissible to any qualified person as necessary, however, such delegation does not relieve the delegator of the overall responsibility.
9. When a paragraph reference is used without a manual or chapter/section reference (e.g., paragraph C 1 a), that reference refers to a paragraph within that same section. If the reference is to another manual, chapter or section, that manual/ chapter/section will be referenced (e.g., MOCPM 03-08).
10. Abbreviations and Acronyms: The Acronym List [Ref. GPM 00-02] is not all-inclusive. Acronyms may be defined in the section used. Additionally, any acronym or abbreviation used in OEM manuals is considered acceptable for use in Company documentation.
11. Standard Aviation Terminology: Use of standard aviation terminology is acceptable. Left and Right are as viewed from the cockpit. Engines, main wheels, and brakes are numbered from left to right, and either “#2 tire” or “left inboard tire” is acceptable. Likewise, “RT” and “RH” indicate “right or right-hand” and are acceptable.
12. Operations Specifications (Ops Specs) define the provisions and limitations under which an air carrier may conduct its operations [Ref. FAA Order 8900.1 Volume 3, Chapter 18]. Ops Spec requirements within this manual are identified by listing the Ops Spec number in parenthesis adjacent to the associated text, table or graphic. Example: (Ops Spec D085) or (Operations Specification D085). When identified in this manner the reader is being alerted that the information relates to an Operations Specification requirement and that compliance is mandatory [Ref. 14 CFR 119.43(b)(2)]. This method satisfies the requirement for Envoy to inform its employees and other persons used in its operation of the provisions of its operations specifications that apply to that employee or that person’s duties and responsibilities [Ref. 14 CFR 119.43(c)].

END

STANDARDS FOR FUEL PROVIDERS

CONTENTS

01-01.A	General	1
01-01.B	Policy	1
01-01.C	Procedures	1

A. GENERAL

1. All fuel providers are responsible for complying with the procedures set forth in this manual when performing fueling on aircraft operated by Envoy Air Inc.
2. The fuel quality control standards in this section are based on ATA Specification 103 Standard for Jet Fuel Quality Control at Airports.

NOTE

At international stations (using ATA 103 as a guideline) an auditor/inspector must use the Envoy Fueling and Servicing Procedures Manual (FSPM) as a guideline to perform an inspection.

3. For additional information or classification of current guidelines to be used, contact DMSC.
4. Written procedures for fuel storage facilities and refueling vendors providing services to Envoy aircraft may be used in lieu of this manual upon written approval by the Envoy DMSC. Refer to FSPM 02-01 for procedures to request approval of an alternate procedure.
5. Notification of an FSPM revision is sent via email to all manual holders.

B. POLICY

1. Audits of fuel storage facilities, refueling units and into-plane operations are performed every two years at all Envoy stations. Additionally, the audits performed by the fuel vendor personnel as well as personnel qualification (training) records shall be audited. Audits are performed in accordance with this manual and the Envoy CASS Manual.

NOTE

Envoy accepts AA Fuel Audit Policies and Procedures. MSC may accept fuel audits performed by AA at joint stations upon satisfactory review of AA fuel audit.

2. Envoy recognizes that fuel providers at international stations must comply with international standards. However, all fuel provider personnel must understand that compliance with international standards is not a substitute for compliance with the standards set forth by Envoy.

C. PROCEDURES

1. The FSPM mandates inspections and self-audits which are conducted by station management and fuel vendor personnel.
2. The station General Manager is responsible for ensuring that inspections/audits performed by station personnel are accomplished in a timely manner, and that records of these audits are maintained for the prescribed time.
3. The ranking official at the fuel vendor is responsible for ensuring that inspections/audits performed by fuel vendor personnel are accomplished in a timely manner, and that records of these audits are maintained for the prescribed time.
4. Fueling audits shall be performed by Envoy CASS Auditors in accordance with the schedule prepared by the DMSC.

END

PERSONNEL QUALIFICATIONS

CONTENTS

02-00.A	General	1
02-00.B	State Driver's License	1
02-00.C	Training	1
02-00.D	Fuel Vendor Training Record	2
02-00.E	Designated Trainer Authorization Form	4

TABLES

Table FSPM 02-00.a	Instructions for Completing AE-FSPM-0200 Fuel Vendor Training Record	2
Table FSPM 02-00.b	AE-FSPM-0200 Fuel Vendor Training Record	3
Table FSPM 02-00.c	Instructions for Completing AE-FSPM-0200.1 Designated Trainer Authorization Form	4
Table FSPM 02-00.d	AE-FSPM-0200.1 Designated Trainer Authorization	4

A. GENERAL

1. The following outlines the training, qualifications and authorization applicable to personnel who fuel Company aircraft as required per 14 CFR 121.105 and 121.123.
2. Fuel vendors are responsible for maintaining a training program and providing the local Company General Manager with an updated list of their employees who are qualified to service each type of Company aircraft. This list is to be updated each time a change in qualified personnel occurs or annually, whichever occurs first.

B. STATE DRIVER'S LICENSE

1. Each authorized driver must have a currently valid state driver's license.
2. Vendor management is responsible for performing an annual driver's license review for any operator of a motorized vehicle engaged in the servicing operation of Company aircraft. Any driver whose state driver's license has expired or has been suspended or revoked shall not operate motorized vehicles in the servicing operation of the Company aircraft.
3. The annual driver's license review shall be documented on the Fuel Vendor Training Record (AE-FSPM-0200).

C. TRAINING

1. The following training must be accomplished and documented to qualify personnel to fuel Envoy aircraft. In accordance with the vendor's training program, personnel are to be trained:
 - a) On each type of vehicle that they will operate regardless of previous experience. Particular emphasis should be placed on brake checking, defensive driving, allowing adequate braking distance, and (if equipped) backup camera usage.
 - b) In the safe and efficient fueling of aircraft. Particular emphasis should be placed on adhering to fueling procedures and recognizing normal fueling operations versus malfunctions that require emergency or maintenance action.
 - c) In fire safety.
 - d) In each type of fuel quality testing they will perform.
 - e) On each type of fuel storage facility equipment they will maintain and/or operate.
2. An Envoy MSC auditor/trainer shall provide initial FSPM and fleet-specific training to "designated trainers." As new aircraft types are operated into a given station, the MSC auditor/trainer or authorized designated trainer will provide additional fleet-specific training as may be required.
3. Envoy may authorize vendor personnel to act as designated trainers using the Designated Trainer Authorization (AE-FSPM-0200.1).
 - a) Designated trainers will be trained by aircraft type and authorized to train other vendor personnel (e.g., new hires, transfers, etc.) who may be assigned to service Company aircraft.
4. In accordance with Envoy Fuel Vendor Training Program, each designated trainer will be required to:
 - a) Complete Envoy Course MTX0408 as initial training and obtain a Designated Trainer Authorization AE-FSPM-0200.1 signed by an Envoy MSC auditor/trainer.
 - b) Complete Envoy Course MTX0408 as recurrent training once every 24 months (or whenever course is revised, whichever is sooner).

Fueling and Servicing Procedures Manual

5. In accordance with Envoy Fuel Vendor Training Program, other fuel vendor employees must complete the following training to qualify them to fuel Envoy aircraft:
 - a) Initial Training
 - 1) Review of Envoy Course MTX0407 with documentation of compliance on Form AE-FSPM-0200.
 - 2) Proficiency review, consisting of driver's license verification and observation of job performance. This proficiency review is to be documented on the Fuel Vendor Training Record (AE-FSPM-0200).
 - b) Annual Training
 - 1) Proficiency review, consisting of driver's license verification and observation of job performance. This proficiency review is to be documented on the Fuel Vendor Training Record (AE-FSPM-0200).
 - 2) If the employee is not considered proficient, he shall be re-trained and re-qualified in accordance with the above procedures.
 - c) Recurrent/Revised Training
 - 1) Complete Envoy Course MTX0407 as recurrent training once every 24 months or whenever course is revised, whichever is sooner.
 - 2) Updated MTX0407 Certificate should be retained in employees training file until superseded.
6. Upon completion of Envoy-provided training:
 - a) Designated Trainer Authorization Record (AE-FSPM-0200.1) is to be completed and retained in designated trainer's employee training record.
 - b) Fuel Vendor Training Record (AE-FSPM-0200) is to be completed and retained in the fuel vendor employee's training record.
7. After initial training, prospective personnel must be observed by an MSC auditor/trainer or designated trainer to demonstrate their proficiency.

NOTE

Following initial training provided by an Envoy MSC auditor/trainer on at least one of the Envoy fleet types, the designated trainer is thereby qualified to provide initial training and perform annual proficiency reviews for their employees on all fleet types operated by Envoy.

D. FUEL VENDOR TRAINING RECORD

1. Fuel Vendor Training Record (AE-FSPM-0200) is completed as follows:

Table FSPM 0200.a: Instructions for Completing AE-FSPM-0200 Fuel Vendor Training Record

ITEM	DESCRIPTION	RESPONSIBILITY
a)	Enter name of employee being trained.	Designated Trainer
b)	Enter the name of the company that fueler works for.	Designated Trainer
c)	Enter city code.	Designated Trainer
d)	Verify/observe each task or requirement and indicate whether satisfactory using Yes or No blocks.	Designated Trainer
e)	Employee must sign each line next to the aircraft type that he has been trained to service.	Employee
f)	Trainer/designee must sign each line which contains the aircraft type that he has trained the employee to service.	Designated Trainer
g)	Enter date training was completed.	Designated Trainer
h)	Enter name of trainer/designee performing annual driver's license/proficiency review.	Designated Trainer
i)	Enter date the annual driver's proficiency review was accomplished.	Designated Trainer

Fueling and Servicing Procedures Manual

Table FSPM 0200.b: AE-FSPM-0200 Fuel Vendor Training Record

AE-FSPM-0200 07 Apr 20		Envoy Air Inc. FUEL VENDOR TRAINING RECORD	
This form is to acknowledge that _____ (a) _____, employed by _____ (b) _____ at _____ (c) _____ has completed formal training on Envoy Air Inc., Fueling and Servicing Procedures Manual, has demonstrated proficiency on Fueling Procedures and is authorized to service the Envoy Air Inc. aircraft as indicated below.			
	Yes	No	Aircraft Fueling and Servicing Procedures
1.	(d)		Initial Course MTX0407 completion date: _____ Recurrent/Revised MTX0407 training, last completed date: _____ [Ref. 02-00 C.5.c)]
2.			Demonstrate access/login to Envoy Technical Publications web page with access to Envoy Fueling/ Servicing Procedures manual.
3.			State driver's license valid and current [Ref. 02-00 B.1.].
4.			Understands operating instructions, warnings and precautions.
5.			Recognized the difference between normal aircraft fueling operations versus malfunctions [Ref. 02-00 C.1.b)].
6.			Can explain fire safety precautions and procedures [Ref. 02-00 C.1.c)].
7.			Understands fuel quality testing they will be required to perform [Ref. 02-00 C.1.d)].
8.			Can operate each piece of equipment they will maintain and/or operate [Ref. 02-00 C.1.e)].
9.			Driver stopped at 8 feet and proceeded at walking speed [Ref. 02-03 B.3.].
10.			Distance of at least 5 feet was maintained between the vehicle and aircraft [Ref. 02-03 B.4.].
11.			Vehicle was positioned at least 10 feet from all aircraft fuel vents [Ref. 02-03 B.5.].
12.			Vehicle was positioned correctly [Ref. 02-03 B.6.-12.].
13.			Aircraft and vehicle properly chocked [Ref. 02-03 B.12. (See NOTE)].
14.			Aircraft and vehicle were properly bonded prior to and during fueling [Ref. 02-04 C.1-3.].
15.			Aircraft was fueled per FSPM instructions [Ref. 05-00, 05-01, 05-03].
16.			Fueler monitored pressure gauges during refueling-maximum pressure not exceeded [02-03 B.12.].
17.			Deadman control used properly [Ref. 03-07 B.4.].
18.			Servicing mat properly positioned for overwing fueling [Ref. 02-02 E.3., 05-00, 05-01, 05-03].
19.			Aircraft de-energized and access door/filler cap properly closed [Ref. 05-00, 05-01, 05-03].
20.			Bonding cable removed after all fueling equipment was disconnected [Ref. 05-00, 05-01, 05-03].
21.			All precautions observed during fueling [Ref. 02-02 E.1-4.].
Aircraft Type		Trainee Signature	Trainer/Designee Signature
EMB 140/145		(e)	(f)
ERJ-170/175			
Retain this form in the Employee's Training Record.			

Fueling and Servicing Procedures Manual

E. DESIGNATED TRAINER AUTHORIZATION FORM

1. Designated Trainer Authorization Form (AE-FSPM-0200.1) is completed as follows:

Table FSPM 0200.c: Instructions for Completing AE-FSPM-0200.1 Designated Trainer Authorization Form

ITEM	DESCRIPTION	
1)	Enter the name of the person who is the Designee.	MSC Auditor/Trainer
2)	Enter the name of the company the Designee works for.	MSC Auditor/Trainer
3)	Enter the city code.	MSC Auditor/Trainer
4)	Enter date the Designee is authorized to perform training to fellow employees.	MSC Auditor/Trainer
5)	Designee must sign each line next to the aircraft type that he has been trained to service.	Designee
6)	Trainer/Designee must sign each line containing the aircraft type that he has trained the employee to service.	MSC Auditor/Trainer
7)	Enter date training was completed.	MSC Auditor/Trainer

Table FSPM 0200.d: AE-FSPM-0200.1 Designated Trainer Authorization

AE-FSPM-0200.1 07 Apr 20	Envoy Air Inc.		
DESIGNATED TRAINER AUTHORIZATION			
This form is to acknowledge that (name) _____ (1) _____, employed by (fuel vendor) _____ (2) _____ at (station) _____ (3) _____ is authorized effective this date _____ (4) _____ to administer training to fellow employees on Envoy Air Inc., Fueling and Servicing Procedures Manual and fueling procedures for the Envoy Air Inc. aircraft as indicated below.			
Aircraft Type	Designee Signature	Trainer Signature	Date Trained
EMB 140/145	(5)	(6)	(7)
ERJ-170/175			
Retain this form in the employee's training record.			

NOTE

Retain completed form in the employee's training record.

END

ALTERNATE PROCEDURES

CONTENTS

02-01.A	General	1
02-01.B	Procedures	1
02-01.C	Sample Request for Alternate Procedures (Vendor)	2
02-01.D	Sample Response for Alternate Procedures (Company)	3

A. GENERAL

1. Alternate Procedures may be granted to any of the polices and procedures in this manual due to extenuating circumstances if they do not compromise fuel quality, safety or security.
2. For any information concerning Alternate Procedures issued to a particular station, contact MSC via email.

B. PROCEDURES

1. Requests for Alternate Procedures are to be submitted in writing to the Company and contain pertinent details and justifications. See example in paragraph "Sample Request for Alternate Procedures (Vendor)" ([p 2](#)).
2. DMSC is to review, evaluate and respond to each Alternate Procedures request. See example in paragraph "Sample Response for Alternate Procedures (Company)" ([p 3](#)).
 - a) If approved, authorization will be sent to the vendor. Approval must:
 - 1) Be in writing.
 - 2) Specify an expiration date.
 - 3) Specify any related stipulations.
 - b) If not approved, vendor will be contacted with a reason for disapproval.
3. Disposition
 - a) Vendor
 - 1) All Alternate Procedures granted to a vendor, which authorizes variations to this manual, are to be maintained by the affected vendor with the request for the variation as long as they are effective. These are to be made available for review upon request by the Company.
 - 2) Establish a follow up system to purge out-dated material.
 - b) Company
 - 1) The MSC Vendor File shall contain copies of all Alternate Procedures requests and approvals.
 - 2) Disapproved and expired requests shall be discarded.

CONTINUED ON FOLLOWING PAGE

Fueling and Servicing Procedures Manual

C. SAMPLE REQUEST FOR ALTERNATE PROCEDURES (VENDOR)

(Vendor Letter Head)

(Date)

Director Maintenance Safety and Compliance
Envoy Air Inc.
4301 Regent Blvd. MD 220
Irving, TX 75063

RE: Request for Alternate Procedures
Fueling and Servicing Procedures Manual Chapter/Section: _____
Subject Title: _____
Airport: _____
Effective Through: _____

Dear _____:

Your airline has adopted as part of its manual certain provisions relating to Inspection Tests and Safety Procedures which are intended to preclude the introduction of contaminated or impure fuel into the airline's aircraft. (Vendor) is unable to comply with the designed subsection of the airline's manual reference above at the designated airport for the following reasons:

(Describe why unable to comply.)

However, in order to ensure that an equivalent level of (Indicate fuel quality, safety or security) to that prescribed in the manual, (Vendor) proposes to adopt the following Inspection Procedures at that airport until the date above when it will be in compliance with the manual:

(Describe substitute procedures. For example, who will be responsible and accountable for it? How will the procedure be controlled?)

Accordingly, (Vendor) hereby requests that it be granted an alternate procedure by the airline from the provisions of the manual referenced above.

(Signature)
(Typed Name)
(Title)

Fueling and Servicing Procedures Manual

02-01
Page 3 of 3
05 May 15

D. SAMPLE RESPONSE FOR ALTERNATE PROCEDURES (COMPANY)

(Envoy Letter Head)
(Date)
(Vendor Name)
(Address)
(City, State Zip)
RE: Grant of Alternate Procedures Fueling and Servicing Procedures Manual Chapter/Section: _____ Subject Title: _____ Airport: _____ Effective Through: _____
Dear _____:
By letter dated _____, you have requested an Alternate Procedure from the provisions of the subsection of the Company's manual referenced above with respect to operations at the specified airport. In addition, you identified procedures or tests you will substitute for those specified in the manual which you state will ensure that the requisite fuel quality and purity will be achieved. The Company finds these procedures acceptable.
Accordingly, the Company hereby approves the Alternate Procedure from the manual subsection as described in the reference above, subject to the condition that the substitute procedures or tests will remain in effect during the entire period, as described in your letter.
(List any stipulations.)
(Signature)
(Typed Name)
(Director Maintenance Safety and Compliance)

END

FUEL PROPERTIES AND SAFETY PRACTICES

CONTENTS

02-02.A	General	1
02-02.B	Safety Management System (SMS)	1
02-02.C	Fuel Properties that Influence Fire Hazards	1
02-02.D	Health Hazards	3
02-02.E	Precautions	3
02-02.F	Emergency First Aid	5

TABLES

Table FSPM 02-02.a	Sea Level Temperature Flammability Range	2
Table FSPM 02-02.b	Applicable Vapor Pressures (In psia – Pounds per Square Inch Absolute)	3

A. GENERAL

1. This section contains safety information about fuel properties that influence fire hazards, health hazards, first aid, and precautions to prevent fires, reduce health hazards, and those required during aircraft and GSE servicing.
2. Further, this section outlines Envoy's Safety Management System as it relates to fueling safety.
3. As stated in the Safety Letter, Envoy's first and top priority is the safety and security of our co-workers and customers. This also includes fuel providers. The Company strives to be the world leader in safety and to be recognized for running a safe operation which is a key to our success.
4. For additional information regarding jet fuel, refer to the Material Safety Data Sheets (MSDS) which contain information not limited to:
 - a) Hazardous components
 - b) Physical characteristics (density, flash point, etc.)
 - c) Physical hazards (fire, explosion, reactivity)
 - d) Health hazards (both chronic and acute)
 - e) Permissible exposure limits
 - f) Any applicable precautions (gloves, goggles, fume hood, etc.)
 - g) First aid and emergency procedures (chemical splash, spill handling, etc.)

B. SAFETY MANAGEMENT SYSTEM (SMS)

1. As a Company, we are committed to a culture of safety, security and quality as fundamental priorities. We meet this commitment by ensuring sufficient resources are available to develop, implement, maintain and continually improve our level of safety through SMS and strategies and processes aimed at achieving the highest level of safety performance.
2. To continually reach our safety commitments, we promote, support, enforce and enhance SMS and rely on the sound judgement and experience of our support team members. Safety must be the first and foremost consideration in every decision and in every facet of each individual's duties when providing fueling services to the Company.
3. The role of the fuel provider is to assist in preventing accidents, injuries and unlawful interference with airline operations by adhering to the safety standards stated within this manual, as well as all vendor safety policies and procedures.
4. In supporting these responsibilities, prior to performing any fuel function, each employee shall ensure the fueling function requested can be accomplished safely and in accordance with this manual and training received from the vendor's company.
5. Vendor employees shall report all safety and security issues (including close calls/near misses) that may occur while performing their duties and services to our company.
6. Positive support of all safety initiatives will enhance our companies' top priority of safety and security of ground support personnel, our customers and the equipment we operate.

C. FUEL PROPERTIES THAT INFLUENCE FIRE HAZARDS

1. Flash point

- a) The flash point is the lowest fuel temperature at which ignition can occur. The minimum flash point of Jet A and Jet A-1, 38°C (100°F), is usually above the normal fuel handling temperatures and sea level pressures experienced. However, where the possibility exists that Jet A or Jet A-1 may be heated to or above its flash point, there is danger that the resulting vapors can form ignitable mixtures. This condition may develop within a tank truck which is parked in the sun for extended periods or where ambient temperatures remain in the 38°C (100°F) range or above for extended periods.
2. Flammability range
- a) Flammability range refers to the range of hydrocarbon vapor concentration in a vapor-air mixture within which ignition may occur. The “lower flammable limit” represents the minimum vapor concentration that will be flammable, and the “upper flammable limit” represents the maximum concentration of fuel vapors which will support combustion. Vapor concentrations outside of this range will be either too lean or too rich to support combustion.
- b) The upper and lower flammability limits for hydrocarbon liquids are a function of the temperature and pressure conditions at which they are stored, as well as their vapor pressures.
- c) It is often convenient and more significant to express the flammability range as a temperature range at atmospheric pressure within which it is possible to have flammable vapor-air mixtures as indicated below.

NOTE

Jet B type fuel's flammability range is similar to normal occurring ambient temperature conditions. The following table shows the change of vapor flammability limits as a function of altitude.

Table FSPM 0202.a: Sea Level Temperature Flammability Range

	MINIMUM	MAXIMUM
Aviation Gasoline	-47°C (-50°F)	-1°C (+30°F)
Jet B	-34°C (-30°F)	+24°C (+75°F)
Jet A, Jet A-1	+35°C (+95°F)	+74°C (+165°F)

FIGURE FSPM 02-02A: FLASH POINT TEMPERATURE RANGE FOR COMMON FUELS

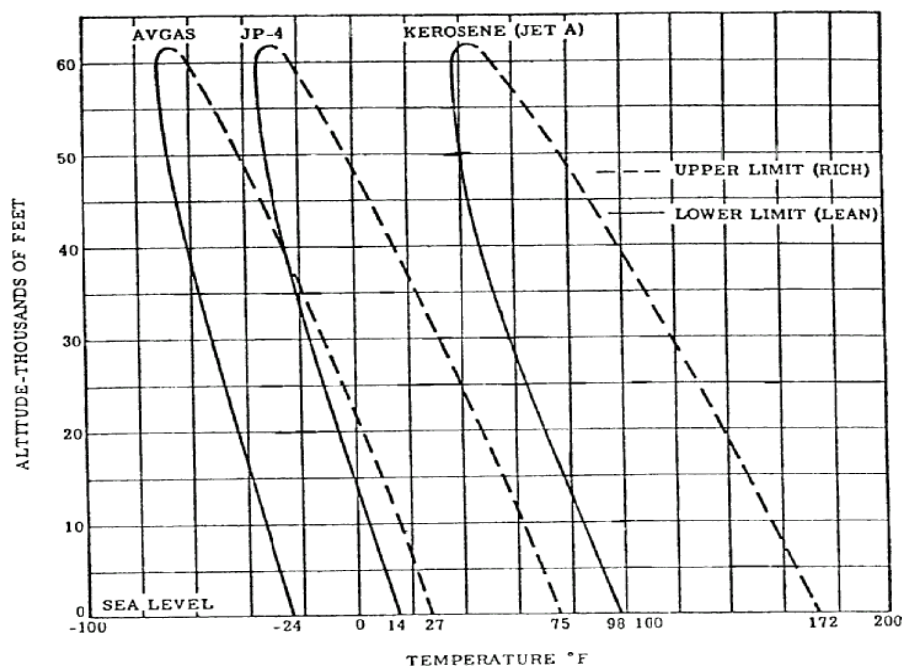

3. Vapor pressure

- a) Vapor pressure is the pressure exerted by a vapor when in equilibrium with its own liquid form. Vapor pressure is a function of the fuel composition and temperature. For aviation fuels, the vapor pressure is measured by the Reid or Micro Method at 38°C (100°F) (ASTM D-323, D-2551).
 - 1) Because of high vapor pressure of aviation gasoline, it emits flammable vapors in ignition amounts at normal temperatures and pressures.
 - 2) Jet A and A-1 do not give off flammable vapors in ignitable amounts unless the fuel temperature is about 35°C (95°F) or above.
- b) When these vapors are confined in a closed vessel, the vapor-air mixture over the liquid surfaces are usually too rich to be ignited (being above the upper flammability limit).

Table FSPM 0202.b: Applicable Vapor Pressures (In psia – Pounds per Square Inch Absolute)

Aviation Gasoline	5.5 to 7.0
Jet B	2.0 to 3.0
Jet A and Jet A-1	Below 0.1

- c) Due to the intermediate vapor pressure of Jet B and JP-4, the vapor-air mixture above the liquid surface under normal temperature and pressure conditions will most frequently be within the flammability range.
- ### 4. Other contributing properties causing fire hazard in aviation fuels are:
- a) **Auto-ignition Temperature** – Minimum temperature required in a substance to initiate or cause self-sustaining combustion independently of any sparks or other means of ignition.
 - b) **Distillation Range** – The overall volatility of a fuel through its entire distillation range is shown by its initial and final boiling points – a factor distinct from the flash point and vapor pressure.
 - c) **Electrostatic Susceptibility** – The degree to which aviation fuels acquire and build up a static charge depends upon many factors, such as fuel type, amount and type of impurity, linear velocity in pipes, hoses, and filters, type and condition of charge, separating surface, conductivity and treating reagents.

D. HEALTH HAZARDS

1. Turbine fuel and oil can be irritating to the eyes and skin and poisonous when taken internally. Every effort should be made to avoid contact with the skin or eyes.
2. Fuel Odor
 - a) Jet fuel produces a distinct odor which can range from relatively mild or sweet to moderately objectionable. ASTM Specification D-1655 states that fuel shall not produce an odor which is “nauseating or irritating.”
 - b) During all phases of fuel handling, sampling and testing, personnel should avoid excessive breathing of vapors but remain aware of fuel which produces an unfamiliar odor requiring further investigation.

E. PRECAUTIONS

1. Precautions to Reduce Health Hazards
 - a) Wear natural fiber clothing (such as cotton). Do not wear synthetic textiles (such as nylon). Synthetic clothing not only can generate electrostatic charges, but also constitutes a serious hazard in the event of a fire, when synthetic textiles can weld into burned skin and cause dangerous side effects. Cotton and other natural fibers do not present these hazards.
 - b) Wear protective goggles with shatterproof lenses when stationed “under wing” during a fueling operation.
 - c) Never wear fuel- or oil-soaked clothing.
 - d) Wear suitable pressurized breathing apparatus if entry into a gaseous environment must be made. Have an additional person with the same or similar equipment stationed outside the high vapor level environment to give assistance in case of an emergency.
 - e) Wash hands after contact with aviation products, especially before putting food, cigarettes or anything else in mouth.

- f) Never put petroleum soaked rags in pockets.
 - g) If it becomes necessary to siphon product from a tank through a rubber hose, use a suction pump or similar device. Under no circumstances should siphon tubes be placed in the mouth.
2. Precautions to Prevent Fires
- a) Observe local fire laws, regulations and published procedures.
 - b) If, in the opinion of local management, a sufficiently hazardous operation is being conducted, the Fire Department should be requested to stand guard.
 - c) Smoking and open flames of any kind are prohibited near fuel storage facilities, fueling equipment or other hazardous locations and in or near aircraft on the ground.
 - d) No Smoking signs must be posted in cabs of fuel servicing vehicles. Lighters and ash trays must be removed or made inoperative.
 - e) "Strike Anywhere" matches are prohibited on the airline premises or aircraft.
 - f) Matches or cigarette lighters are not to be carried in breast pockets.
 - g) The use of flash bulbs or floodlights (except explosion proof) are not permitted in the immediate vicinity of fuel servicing operations or of flammable liquid spills.
 - h) Flammable liquids have the ability to produce and retain static electricity. Bonding in accordance with the procedures in Chapter 5 of this manual will minimize the possibility of a static spark during fueling.
 - i) Fire prevention requires the highest standards of maintenance for fuel servicing vehicles, equipment and installations. Leaks are a particular hazard and must be corrected at once.
3. Precautions Required During Aircraft Servicing
- a) Fueling operations shall not be conducted when thunderstorms with lightning are observed within five miles of the airport. All fueling operations are prohibited if such storms are reported as severe.
 - b) All unnecessary electrical equipment, such as rotating beacons and strobe lights, will be turned OFF before fueling operations are started. No avionics will be activated during fueling operations.
 - c) Do not operate aircraft radio, radar or any other electrical/electronic equipment on aircraft during fueling operations, except as specified.
 - d) Ground equipment is not to be positioned under wing tips during fueling operations. The wings are deflected downward during fueling with the wing tips deflected the most. Equipment must also remain clear of aircraft movable surfaces.
 - e) Ensure aircraft is electrically safe and fueling vehicles are properly bonded to aircraft to prevent fire or explosion due to the discharge of static electricity.
 - f) If a circuit breaker is tripped, trips or opens during fueling operation, notify flight crew immediately. Do not start or resume fueling operations until corrective action has been taken.
 - g) Make sure that all the switch guards are at the closed position on the refueling panel.
 - h) Before placing servicing mats over wing skins, ensure that wing skins are dry and mats are dry and uncontaminated. Do not leave servicing mats in position on completion of work as this could result in surface corrosion.
 - i) Do not use metallic materials such as screwdrivers, etc. to remove fuel caps. This results in damage to the caps.

NOTE

If the use of a tool is absolutely necessary, a tool made of non-metallic material such as wood or plexiglass is authorized.

- j) Make sure that the fuel nozzle does not touch the bottom of the fuel tank. The fuel nozzle can break the protective coating in the tank. Damage to protective coating can cause corrosion.
- k) **Any** damage incurred (such as dropping the fuel nozzle on the wing, or scratching the painted surface), **must be reported** to the Flight Crew immediately.
- l) If any fuel spillage occurs, terminate fueling and follow the procedures in FSPM 02-05. Do not start or shut down APU should fuel spill occur [Ref. FSPM 02-05].
- m) Vendor employees may use electronic devices issued by the vendor for related business. They may also use personal one way non-text pagers. No other personal electronic devices (PED) may be used by employees while performing job tasks. This includes cell phones, CD players, or portable DVD players.

4. Precautions Required During Servicing of Ground Equipment

- a) Tank vehicles used for fueling ground equipment must comply with the requirements the National Fire Protection Association's No. 385 Recommended Regulatory Standard for Tank Vehicles for Flammable and Combustible Liquids.
- b) Fill or drain fuel tanks outdoors only.
- c) Designated locations for fueling ground equipment should be established. These locations should be at least 25 feet from any hangar opening.
- d) Fueling of ground equipment should not be done within 50 feet of an aircraft.
- e) In an emergency, not over two gallons of fuel may be used to service a vehicle that is out of fuel to get it started. Use an approved safety can.
- f) Do not fuel ground equipment between the aircraft and the gate during enplaning or deplaning of passengers at ground level.
- g) An adequate dry chemical fire extinguisher must be readily accessible when fueling ground equipment. For fuel pumps this should be located near the emergency shut-off, but in no case further than 100 feet from the pump. Tank trucks used for fueling ground equipment must have an adequate dry chemical fire extinguisher.
- h) Where cans are used for fueling ground equipment, they must be safety cans with self-closing caps, flame arresting screens and flexible dispensing hose.
- i) Fuel tanks of all ground equipment, except standard passenger vehicles, must have a self-closing fill and vent cap that fastens securely. Repair cap if spring is broken and/or if cap is loose or damaged.
- j) Do not fuel a vehicle with the engine running.
- k) If fueling fitting is adjacent to a battery, the battery cover must be in place, to prevent the possibility of sparking due to inadvertent contact of the nozzles.
- l) Watch progress of filling of fuel tank to avoid overflow. If an overflow occurs, accomplish the following:
 - 1) Clean up any spilled fuel before starting the engine.
 - 2) Provide a fire guard until spilled fuel is cleaned up.
- m) Fueling nozzles must be self-closing. Nozzles with notches or hold open latches (including latch-open automatic nozzles) shall not be used. Blocking nozzles open is strictly forbidden.
- n) Maintain contact between nozzle and fuel tank body, to minimize the accumulation and discharge of static electricity.
- o) Check that fuel tank cap is secure before starting the engine.
- p) Smoking or open flames within 50 feet of vehicle fueling operations are forbidden.

F. EMERGENCY FIRST AID

1. Wash immediately with soap and water any part of the body that comes in contact with turbine fuel or oil.
2. If any turbine fuel or oil is swallowed, call a doctor immediately. **Do not induce vomiting.**

END

FUEL SERVICING VEHICLES

CONTENTS

02-03.A	General	1
02-03.B	Vehicle Safety	1

A. GENERAL

1. This section outlines the Company's policy for positioning of fuel service vehicles and motorized ground equipment in relation to aircraft.
2. Drivers must:
 - a) Observe traffic regulations and airport driving rules. They must control speed according to conditions.
 - b) Notify their supervisor, at once, of any accident in which they are involved, regardless of whether or not it resulted in injury or damage, and submit required reports.

B. VEHICLE SAFETY

The following apply to vehicles used to fuel or support servicing of Envoy aircraft.

CAUTION

Never position fueling vehicle(s)/cart(s) next to an aircraft until the engines are shut down and rotating beacon(s) are turned off.

1. Aircraft always have the right of way. Do not approach an arriving aircraft until it has come to a complete stop on the designated parking spot.
2. OSHA regulations require that all occupants (driver, passenger, etc.) of all vehicles must use seat belts when vehicles are in operation.
3. Accelerate slowly and stop slowly. Drivers must come to a complete STOP at eight feet when approaching an aircraft. After stopping, proceed at walking speed to refueling position.
4. A distance of at least five feet shall be maintained between the fuel servicing vehicle and any part of the aircraft at all times.

NOTE

Local conditions may not allow the required five feet of clearance between the fuel servicing vehicle and any part of the aircraft. The Regional VP may provide a waiver granting approval at those locations. That waiver shall be in the form of a letter identifying the specific parking spots, and any additional safety measures to be utilized at those locations to prevent damage to the aircraft. A copy of that letter shall be maintained by the station manager and be made available upon request by a representative of Company management or the FAA.

5. Do not position the fuel servicing vehicle within 10 feet of aircraft fuel system vent openings.
6. Equipment must never be parked so that damage could result if an aircraft should settle. Never park under any part of the aircraft fuselage, wing, or **any part** of the tail.
7. At any gate where space permits, fuel servicing vehicles should be positioned parallel to the aircraft fuselage, outside the right wing tip when fueling.

NOTE

At locations where the servicing vehicle drives forward after fueling, they should be parked so the aft end of the vehicle is far enough forward of the wing tip to eliminate the possibility of the rear of the truck striking the wing as the vehicle departs the area.

8. If parallel parking is not possible, vehicles should be positioned at an angle between the right wing and aircraft fuselage with their front wheels turned away from the aircraft.

NOTE

The front of the vehicle should preferably be pointed away from the aircraft so that damage is avoided in the event the vehicle rolls.

9. Whenever a fuel servicing vehicle has to back up, either to approach the aircraft or to depart the aircraft, guidance must be sought by the driver and guidance must be provided by ramp personnel at that gate or any personnel from adjacent gates, before the vehicle operator is allowed to back the vehicle.
10. If a fuel servicing vehicle is equipped with an operative rear backup camera, the operator of that vehicle may use the camera in lieu of a guide person to reverse the vehicle, provided that all of the following conditions are met:
 - a) The vehicle is not reversing toward an aircraft.
 - b) The vehicle is not operating within five feet of an aircraft surface.
 - c) The vehicle is not operating in areas that are congested or where visibility is obstructed.
11. If there is any doubt about clearance, use a guide person. The guide person is to stand where he can judge clearances and is in full view of the driver. If the guide person's view becomes obscured, he must give the STOP signal and reposition himself. The driver should proceed only while he receives a continuous signal to do so. Driver must stop at once if the driver loses visual contact with the guide, if the guide stops signaling or if there is any question in his mind as to the safety of the operation.

NOTE

Although a guide person is used, the driver is still responsible for the safe operation of the vehicle.

12. As soon as any vehicle is stopped in position at an aircraft or parked, shift to NEUTRAL or PARK immediately. Do this before attempting to operate any other controls to avoid "foot slipped off the clutch" or "wrong gear" accidents. Set the parking brake before leaving the driver's position.

NOTE

If brake safety interlocks are inoperative, wheel chocking procedures must be used until safety interlock system is repaired and operating safely.

13. Aircraft must be chocked correctly.

NOTE

Nose wheels should be chocked "rubber to rubber" (chocks against tires).

14. Fuel servicing vehicles shall be positioned so that the operator can see the nozzle pressure gauge.

END

GROUNDING AND BONDING

CONTENTS

02-04.A	General	1
02-04.B	Bonding Between Fueling Equipment and Aircraft	1

A. GENERAL

1. During fuel servicing operation, there are several possible sources of static.
 - a) The aircraft may be charged.
 - b) Fuel through the hose may generate static.
 - c) Servicing truck may be electrified.
2. The presence of flammable vapors creates a fire hazard. This hazard primarily exists when draining flammable liquids. Safety against fires from static spark ignition depends upon preventing a difference of potential at any point where a spark gap might exist in the presence of flammable vapors therefore, fueling equipment must achieve proper bonding as required by this section.

B. BONDING BETWEEN FUELING EQUIPMENT AND AIRCRAFT

1. Bond the fueling equipment to the aircraft bonding point prior to connection of fueling hoses using any servicing bonding points illustrated in the manual. Refer to FSPM Chapter 5 for specific aircraft servicing bonding point locations.
[Ref. FSPM Chapter 5]

CAUTION

Bonding/Grounding clamps must never be attached to any part of an aircraft, except to the bonding/grounding points provided. Using the bond/ground points prevents scratches or damage to highly stressed aircraft components such as landing gear, which can cause landing gear failure.

2. The bonding connection must be maintained during the entire loading operation and must not be removed until the loading is complete and all fueling equipment has been disconnected.
3. When more than one truck is used during overwing fueling of an aircraft, each truck operator is responsible for the bonding of the fuel equipment to the aircraft.

END

Fueling and Servicing Procedures Manual

GENERAL FUELING PROCEDURES

CONTENTS

02-05.A	General	1
02-05.B	General Procedures – Fueling	1
02-05.C	Emergency Procedures	2
02-05.D	Spill Reporting and Clean-up (Company Management)	3

A. GENERAL

1. Into-Plane Fuel Vendors and Company Station Management must have in-place, and become familiar with, local procedures which govern the handling of fuel spills and include:
 - a) Criteria for notification of local Fire Department.
 - b) Criteria for passenger deplaning.
 - c) An up-to-date list of applicable personnel to be notified of fuel spill.
 - d) Communications procedures.
 - e) Determining and implementing actions necessary for handling the spill.
 - f) Verifying that the spill is removed and it is safe to resume operations.
2. Each spill must be treated as an individual case because of such variables as weather, equipment arrangement, passenger loads as well as available personnel and equipment. Communication is vital when a spill or a fire occurs. Spills can also be prevented by:
 - a) Guarding against spills from hose breakage, leakage and other fueling equipment failure, by daily inspections and preventive maintenance.
 - b) Exercising caution against over-filling of fuel tanks and truck compartments.
3. For the purposes of the section, hazardous conditions include but are not limited to:
 - a) The fuel spill is over 10 feet in size in any direction, or over 50 square feet in area.
 - b) The flow of fuel cannot be stopped; i.e. the emergency fuel shut-off does not stop the flow of fuel.
 - c) The size and location of the fuel spill and surrounding environment are judged to be hazardous enough to pose a fire threat.
 - d) The fuel spill ignites.

B. GENERAL PROCEDURES – FUELING

1. Envoy considers all aircraft ground time (with or without passengers on board) a fueling/defueling period. Unless otherwise prohibited by local regulations, passengers may remain on board, enplane or deplane during fueling under the following conditions:
 - a) The flight attendant(s) must remain on board, and the main passenger entrance door must remain open with a means for passengers to deplane quickly (i.e., stairs or jetbridge).
 - b) The flight attendant must remain alert to the fueling situation and any potential problems that would necessitate passenger deplaning or evacuation.
 - c) During periods of inclement weather, the door may be positioned (not fully closed) so as to keep rain, etc., out.
2. The fueler is responsible for the fueling operation. The fueler's employer is responsible for ensuring that all employees who fuel Envoy aircraft:
 - a) Have been properly trained.
 - b) Have a clear understanding of all required communication procedures and methods.
 - c) Provides notification when a hazardous condition or situation has been determined to exist.
 - d) Have the ability to execute such procedures in an expeditious manner should a dangerous situation develop.
3. When fueling with passengers on board, the jetbridge or passenger loading stairs must be positioned at an entry door of the airplane and the door will remain open.

4. Pilots are not required to be present during fueling with or without passengers on-board, however, if present, they must ensure that the ability to communicate is maintained (by any suitable means) between the fuel vendor and qualified on-board personnel.
5. Fueling equipment shall not be positioned in a way which would obstruct aircraft emergency exit routes (including evacuation chutes) with or without passengers on board.
6. Smoking is not permitted on the aircraft or on the ramp at any time.

C. EMERGENCY PROCEDURES

1. The following procedure must be followed in the event of a fuel spill, hazardous condition or fire:
 - a) When a problem occurs, the fueller shall:
 - 1) STOP FUELING immediately.
 - 2) Immediately contact fueling supervisor or Dispatch, who will in turn notify Envoy local Operations or Manager-on-Duty.
 - 3) The fueller will inform any local Envoy ground personnel in the immediate gate area.
 - b) When notified by fueller of a problem during fuel servicing:
 - 1) Envoy local operations or Manager-on-Duty shall contact the Fire Department and Flight Crew.
 - 2) Local Envoy ground personnel are to notify the Flight Crew and/or Flight Attendant.

CAUTION

Do not operate, start up or shut down any ground, electrical or communications equipment in the area of the spill. This action may create a spark that can ignite fuel vapors.

NOTE

If a spill ignites, properly trained employees can often extinguish or control a fire while awaiting the arrival of the airport Fire Department.

- c) The flight crew/flight attendants shall be notified in the most expedient manner by use of the aircraft radio communication system, direct person-to-person contact or other method(s) that ensure direct and timely communication through station operations management, maintenance, or other local forms of gate operations control.
 - d) Flight crew/flight attendant shall coordinate with Envoy ground personnel regarding the decision to deplane.
 - e) Passengers must be de-planed if:
 - 1) The flow of fuel cannot be stopped.
 - 2) The size and location of the spill and surrounding environment are judged to be hazardous enough to pose a threat of fire.
 - 3) The fuel spill ignites.
 - f) Never use the word "EVACUATE"; use the word "DEPLANE" when passenger deplaning is needed.
 - g) Never permit anyone to walk in the liquid area of a fuel spill due to extreme hazard in the event of ignition.
2. The flight crew or MOC, as applicable, are responsible for ensuring the appropriate procedures are accomplished for recording of aircraft discrepancies and notifying Maintenance for evaluation and necessary corrective action.
 3. Disposition of Motorized Equipment
 - a) Any gasoline powered equipment that is operating and standing in a fuel spill should not be disturbed because of the danger of backfire or other sources of ignition of the spill resulting from an attempt to move or shut off the equipment. Summon the Fire Department and they will attempt to minimize or eliminate the danger of fuel spill ignition.
 - b) Motorized equipment *outside* of the spill area shall be shut down as quickly as possible depending upon the number of personnel available to handle the fuel spill. It is preferable to remove all equipment from the vicinity of the aircraft.

CAUTION

Motorized equipment operating outside the spill area should be shut OFF slowly by reducing speed to idle before cutting ignition to prevent backfire.

- c) If possible, remove the fuel truck from the spill area. Be sure that hoses are disconnected from the aircraft and ladders are down. Single-point nozzles should be locked into the truck interlock stowing bracket.

- d) Do not shut down an operating aircraft APU should a fuel spill occur. An operating APU will not expel flames if fuel vapors drift into the APU air inlet which is a possibility with a shut down, hot APU.

D. SPILL REPORTING AND CLEAN-UP (COMPANY MANAGEMENT)

Station management personnel must notify Lead EC of all fuel spills, and refer to the AA Environmental Management Manual which addresses spill reporting and clean-up procedures to be followed locally. The station General Manager and local Environmental Coordinator are responsible for following the procedures outlined in the Corporate Safety, Security and Environmental Policies and Procedures Manual and for coordinating clean-up activities with the Into-Plane Fuel Vendor and local authorities as appropriate.

1. **Aircraft Clean-Up** – Collection of fuel within any part of the aircraft structure is extremely hazardous, particularly in such areas as flap wells, nacelles and certain areas inside the wing. Maintenance Operations Control (MOC) must be notified for clean-up instructions.
2. **Cargo Clean-Up** – Carefully examine any baggage, freight or mail sacks on the ramp at the time of the spill. Do not place any cargo on board the aircraft until all evidence of fuel has been removed or allowed to evaporate.
3. **Disposition Of Aircraft** – After the spill area has been cleaned, it may be necessary to tow the aircraft away from the area for boarding of passengers. Check with the local fire authorities to determine if the aircraft must be towed (MOC must be contacted if local personnel are not tow-qualified). If it is not necessary to tow the aircraft to another boarding area, the passengers may be boarded at the same gate or area after the fuel spill has been cleaned. Engines are not to be started until the area has been confirmed to be clean. Local airport regulations may require that permission be obtained from local authorities prior to starting engines. Ensure that tires do not stand on fuel-saturated pavement any longer than necessary since fuel softens rubber.

END

Fueling and Servicing Procedures Manual

NON-LISTED FUELING PROCEDURES

CONTENTS

02-06.A	General	1
02-06.B	Responsibility and Authority	1
02-06.C	Dispatch Procedures	2
02-06.D	Flight Crew Procedures	2
02-06.E	Maintenance Operations Control (MOC) Procedures	2
02-06.F	Non-Listed Fueling Procedures Form (AE-FSPM-0206)	2
02-06.G	Interfacing Procedures	4

TABLES

Table FSPM 02-06.a	Instructions for Completing AE-FSPM-0206 Envoy Non-Listed Fueling Procedures Form	3
Table FSPM 02-06.b	AE-FSPM-0206 Envoy Non-Listed Fueling Procedures Form	3

14 CFR 121.105 and 121.135

A. GENERAL

1. To support Envoy flight operations there are times when the Company may need to:
 - a) Obtain fuel from a local fuel vendor who may not be listed in the Envoy Approved Air Carrier Maintenance Provider (ACMP) list for charter operations or aircraft diversions to cities not listed on Envoy Ops Spec C070. [Ref. Ops Spec C070]
 - b) Elect to tanker fuel through a city due to concerns with the local fueling vendor that must be resolved before further use of that vendor is authorized.

NOTE

For the purposes of this section “tankering fuel” is a term used to define the process of taking on sufficient amounts of fuel so as not to require fuel at certain stations. Specific procedures for those activities are outlined in the Envoy Dispatch Procedures Manual (DPM) and Envoy Flight Manual (FM) Part 1.

2. The procedures in this section serve to provide necessary guidance to Company personnel to ensure the quality of the fuel to be obtained from the vendors can be assured. For the purposes of this section a “Non-Listed station” is a term used to define a city that Envoy does not provide regularly scheduled service to or from and an Envoy qualified and authorized fuel vendor has not been formally audited or added to the Approved ACMP List. [Ref. GPM 04-12]
3. Fuel vendors to be selected for use at Non-Listed stations shall fall into one of the following categories:
 - a) Vendors who provide fueling services to another Title 14 CFR Part 121 Operator.
 - b) Vendors who are nationally recognized and are considered “major” fueling service providers (ASIG, Allied, American Airlines, Landmark, Million Air, Signature Flight Support, Swissport, TAC Air, etc.).
 - c) Vendors who are approved to provide fueling services for Envoy aircraft at other stations or were previously approved by Envoy to provide into-plane fueling services at that station.
 - d) Vendors who are listed in the Coordinating Agency for Supplier Evaluation (CASE) register.
4. These procedures have a direct interface to sections contained herein which have been placed in the Envoy Maintenance Operations Control and Planning Manual (MOCPM), Envoy FM Part 1 and Envoy DPM to provide guidance to organizations covered by those manuals. Any revision to these procedures requires careful review and coordination with the persons responsible for those manuals to ensure the continued consistency of these procedures.

B. RESPONSIBILITY AND AUTHORITY

1. The Director Maintenance Safety and Compliance (DMSC) has the overall responsibility for the Envoy Non-Listed Fueling Process. That includes the authority to establish and/or change policies and procedures with coordination and approval of the Director of System Operations Control and Director of Flight Operations – Technical to ensure they adequately support Envoy airline operations and continue to meet regulatory requirements.
2. The Director of System Operations Control (SOC) has the authority to implement and cancel the use of Non-Listed Fueling Procedures following the guidance contained herein. That includes the authority to revise the Envoy Non-Listed Fueling Procedures contained in the Envoy DPM with coordination and approval of the DMSC and Director of Flight Operations – Technical, as applicable.

3. The Director of Flight Operations – Technical has the responsibility for the Non-Listed Fueling Procedures in Envoy FM Part 1 that relate to flight crew operations. That includes the authority to revise those procedures with the coordination and approval of the DMSC and Director SOC, as applicable.

C. DISPATCH PROCEDURES

1. Refer to DPM Section 08-00.
2. Once notified that an Envoy aircraft will fly a charter to, or is diverting to, a non-listed station, Dispatch will perform the following:
 - a) Review the types in of fueling vendors that could be used and determine what fueling vendor is available and is to be used at that station [Ref paragraph A.3 of this section].

NOTE

Should access to the list of vendors contained in the CASE register be required, contact the Envoy DMSC who has access to that list.

- b) Ensure the required F4 Safety Message (see below) is added to the affected city in the Flight Operating System (FOS) to alert the flight crew of the need to comply with Envoy Non-Listed Fueling Procedures.
- c) Complete the Non-Listed Fueling Procedures Form (AE-FSPM-0206) and forward a copy to the local non-listed station point of contact to alert them of Envoy non-listed fueling requirements [Ref. paragraph “Non-Listed Fueling Procedures Form (AE-FSPM-0206)”].

D. FLIGHT CREW PROCEDURES

1. Refer to FM-1 Section 7-37.
2. When non-listed fuel quality verification is required, the Dispatcher will attach an F4 Safety Message to the inbound and outbound dispatch release for the affected city.
3. The F4 Safety Message will include certain questions, which are to be completed by the Captain to verify the quality of the fuel and safety of the fueling operation. (These questions are replicated on the AE-FSPM-0206 form in this section.)
4. Once the Captain has completed the questions, he will enter the current date and his signature on the dispatch release verifying that all items have been accomplished.
5. At the completion of the checklist, if there are any answers marked “No”, the safety and integrity of the fuel may be compromised. Do not fuel the aircraft with this truck or hydrant.
6. Should a question arise about the quality of the samples, the Captain shall contact DMSC through MOC for clarification.
7. If found satisfactory, ensure the bond between aircraft and truck or hydrant is complete before fueling begins.

E. MAINTENANCE OPERATIONS CONTROL (MOC) PROCEDURES

1. In the event MOC is contacted by SOC or the Captain with questions related to fuel quality, MOC will contact the DMSC to obtain clarification and directions as to how to resolve the issue.

F. NON-LISTED FUELING PROCEDURES FORM (AE-FSPM-0206)

1. The Non-Listed Fueling Procedures Form (AE-FSPM-0206) is intended to serve as a guide to list the specific Non-Listed Fueling Procedures to be used when fueling Envoy aircraft. When the form is needed, it can be filled out on-line or printed and filled out, then electronically transmitted to the local station point of contact to alert them of Envoy Non-Listed fueling requirements.
2. The Envoy Non-Listed Fueling Procedures Form (AE-FSPM-0206) is completed as follows:

CONTINUED ON FOLLOWING PAGE

Fueling and Servicing Procedures Manual

Table FSPM 0206.a: Instructions for Completing AE-FSPM-0206 Envoy Non-Listed Fueling Procedures Form

ITEM	DESCRIPTION	RESPONSIBILITY
a)	Enter current date.	SOC
b)	Enter city name or three digit station identifier.	SOC
c)	Enter name of person form is being sent to.	SOC
d)	Enter contact info for form electronic transmittal.	SOC

Table FSPM 0206.b: AE-FSPM-0206 Envoy Non-Listed Fueling Procedures Form

AE-FSPM-0206
01 Oct 19

**Envoy Air Inc.
NON-LISTED FUELING PROCEDURES FORM**

Date: _____ (a) _____ Station: _____ (b) _____

To: _____ (c) _____ Fax Number or Email: _____ (d) _____

Envoy aircraft being refueled at your station are to be handled following our Non-Listed Fueling Program. Please review the information below to familiarize yourself with our Non-Listed fueling procedures and items the aircraft Captain will be required to ask for your assistance to complete. The following is a list of the items that the Captain will need to verify before accepting fuel from the local fuel vendor:

1. Is the fuel truck placarded for at least one of the following: JET A/JET A1/JP-8?
2. Are there two charged and serviceable fire extinguishers available?
3. Is the fuel truck chocked?
4. Is the bonding cable attached between the fuel servicing vehicle and the aircraft?
5. Request a sample of fuel from the fuel servicing vehicle for visual examination. Is the sample free of undissolved water, sediment and suspended matter, e.g., "Clear and Bright"?

NOTE

The color of the fuel should range from water-white to slight amber (straw) color. There should be no cloudiness or particulate observed.

Notes:

1. At the completion of the checklist, if the Captain has any answers marked "No", the safety and integrity of the fuel may be compromised and he is not allowed to fuel the aircraft with that truck or hydrant. If found satisfactory, ensure the bond between aircraft and truck or hydrant is complete before the fueling begins.
2. Should a question arise about the quality of the sample, the Captain will contact DMSC through MOC for clarification.

Disposition: A copy of the form is to be maintained on file at SOC for 10 days after which it may be discarded.

3. Disposition of the AE-FSPM-0206: A copy of the form is to be maintained on file at SOC for 10 days after which it may be discarded.

CONTINUED ON FOLLOWING PAGE

G. INTERFACING PROCEDURES

1. The publications listed below interface with this section. The PPR is required to review this content, whenever a change is proposed, to assess if an interfacing manual revision is needed.
 - a) Dispatch Procedures Manual, Section 8
 - b) Flight Manual Part 1, Section 7
 - c) MOCPM 02-01 MOC/Planning Department Policy and Functions

END

Fueling and Servicing Procedures Manual

FUEL SERVICE PROVIDER – INTO-PLANE AND STORAGE

CONTENTS

02-07.A	General	1
02-07.B	Fuel Into-Plane and Storage Provider Pre-Qualification/Authorization Process	1
02-07.C	Responsibility and Authority For Qualifying/Authorizing Fuel Service Providers	2
02-07.D	Procedures – Qualifying/Authorizing Fuel Service Providers	3
02-07.E	Process Measurement	3
02-07.F	Use of Fuel Into-Plane and Storage Provider Process	3
02-07.G	Responsibility and Authority For Fuel Into-Plane and Storage Provider Process	3
02-07.H	Procedures – Use of Fuel Into-Plane and Storage Provider	3
02-07.I	Process Measurement	3
02-07.J	Interfacing Procedures	4

TABLES

Table FSPM 02-07.a	Fuel Into-Plane and Storage	1
--------------------	-----------------------------	---

A. GENERAL

1. This section outlines the Fuel Into-Plane and Storage Provider Pre-qualification/Authorization Process.

B. FUEL INTO-PLANE AND STORAGE PROVIDER PRE-QUALIFICATION/AUTHORIZATION PROCESS

1. The purpose of this process is to ensure that fuel providers have the capability, organizational structure, training, staffing, facilities, and knowledge of Envoy’s programs for the work for which they have been contracted.
2. In general, these elements are established through a pre-qualification audit followed (contingent upon passing the audit) by service-specific training on any applicable Envoy procedures and delivery of any relevant maintenance manuals and/or data. Reference the procedures in this section for details specific to each class of maintenance provider.
3. Envoy classifies fuel providers as indicated in the following table:

Table FSPM 0207.a: Fuel Into-Plane and Storage

FUEL SERVICE PROVIDERS – INTO-PLANE AND STORAGE		
Certification	Non-Certificated	
Level of Service Required	Into-Plane Fueling	Ability to provide into-plane fuel servicing for Company aircraft
	Fuel Storage	Ability to provide fuel distribution and storage services
	Facility	<ul style="list-style-type: none"> • Appropriate facilities as required per this manual to support the Airline operation • Must have the ability to access Envoy electronic manuals
	Materials/Equipment	Basic materials and equipment as required per this manual to support routine servicing.
Programs	Fuel Service Providers must meet Programs, Standards and Procedures described in this Manual	<ul style="list-style-type: none"> • Only trained and qualified persons perform servicing on Envoy aircraft. • Fuel Quality Program • Calibrated tooling (when provided) is periodically subjected to inspection and re-calibration using a process which is traceable to National Institute of Standards and Technology (NIST).

Fueling and Servicing Procedures Manual

Table FSPM 0207.a: Fuel Into-Plane and Storage

FUEL SERVICE PROVIDERS – INTO-PLANE AND STORAGE		
Reporting	Servicing Providers must ensure that Envoy is notified should any of the prescribed conditions occur:	<ul style="list-style-type: none"> The service provider is involved in an incident where damage is caused to Envoy aircraft. Change of Designated Trainer. Loss of capability to perform contracted task. Change of name, address or ownership. Change of equipment.
Training Requirements	Personnel authorized to perform fuel servicing must be trained to follow requirements:	<ul style="list-style-type: none"> A Designated Trainer approved to perform Training on Envoy aircraft shall be trained for the work to be accomplished in accordance with Envoy GPM and perform initial training per Web-based Training (WBT) 0408 and submit course completion certificate to MSC.Support@aa.com. Fuelers/drivers must be given an annual proficiency review consisting of driver's license verification and observation of performance documented on Fuel Vendor Training Record AE-FSPM-0200 (Into-Plane only). Fuel storage vendors must maintain a training program and records for personnel who use fueling equipment which qualify them to perform assigned tasks. Fire safety Fuel Quality testing
Technical Data Utilized	Fuel Servicing Providers perform servicing in accordance with:	Envoy FSPM
Conflict Resolution	All conflicts should be resolved through:	The Director Maintenance Safety and Compliance (DMSC)
Oversight	Oversight will be performed by:	<ul style="list-style-type: none"> MSC performs audits per CM 03-00. Station Self-Audits per FSPM 04-00

C. RESPONSIBILITY AND AUTHORITY FOR QUALIFYING/AUTHORIZING FUEL SERVICE PROVIDERS

- The DMSC is responsible for this process. This includes the authority to establish and/or change policies and procedures related to this process.
- The following positions (or persons acting on their behalf) are required to use/support this process by following the procedures outlined in this section and to advise the DMSC when a deviation is necessary:
 - AA Fuel Supply and Purchasing
 - Manager Technical Publications

D. PROCEDURES – QUALIFYING/AUTHORIZING FUEL SERVICE PROVIDERS

1. The DMSC identifies the need for a fuel service provider and initiates MSC Vendor Action Request Form (AE-CM-0300.2).
2. Upon initiating the form (AE-CM-0300.2), the DMSC shall:
 - a) Coordinate with AA Fuel Purchasing for vendor selection.
 - b) Schedule and accomplish an audit of the proposed provider to establish eligibility for use.
 - c) Notify Technical Publications that the provider is eligible to receive Envoy Fueling and Servicing Procedures Manual (FSPM).
3. Perform the audit using the applicable Fuel Into-Plane Audit Checklist or Fuel Storage Checklist available on Tech Pubs website > [MSC > Checklists](#). Document any deficiencies using the Corrective Action Request Form (AE-CM-0300.3) and resolve prior to deeming the vendor eligible for use [Ref. CM 03-00].
4. During the course of the Pre-Award audit, an Envoy MSC Auditor/Trainer shall provide initial FSPM and fleet-specific training to Designated Trainers.
5. After all deficiencies have been resolved, the DMSC shall add the name of the approved provider to the Envoy ACMP List [Ref. GPM 04-12].

E. PROCESS MEASUREMENT

1. MSC shall retain the results of this audit and vendor's response. The timeliness of the vendor to correct deficiencies and quality of work issues may be used to determine a vendor's eligibility for continued use.

F. USE OF FUEL INTO-PLANE AND STORAGE PROVIDER PROCESS

1. The purpose of this process is to ensure that fuel servicing is coordinated in a manner that permits Envoy to maintain control of the airworthiness of its aircraft. By following the procedures contained or referenced in this section, Envoy demonstrates how the oversight required by 14 CFR 121.363 is administered.

G. RESPONSIBILITY AND AUTHORITY FOR FUEL INTO-PLANE AND STORAGE PROVIDER PROCESS

1. DMSC is responsible for the Fuel Into-Plane and Storage process. This responsibility includes the authority to establish and/or change policies and procedures.
2. The following positions (or persons acting on their behalf) are required to use/support this process by following the procedures outlined in this section and to advise the DMSC when a deviation is necessary.
 - a) Station Operations personnel
 - b) Flight Crew members
 - c) Maintenance personnel
 - d) SOC personnel

H. PROCEDURES – USE OF FUEL INTO-PLANE AND STORAGE PROVIDER

1. When a fuel service provider is notified by one of the following individuals, the fuel service provider shall provide service as outlined in this manual.
 - a) Station Operations personnel
 - b) Flight Crew members
 - c) Maintenance personnel
 - d) SOC personnel

I. PROCESS MEASUREMENT

1. MSC shall perform a routine audit of the fuel provider as defined in CM 03-00.
2. MSC shall retain the results of this audit and vendor's response. The timeliness of the vendor to correct deficiencies and quality of work issues may be used to determine a vendor's eligibility for continued use.
3. Station personnel shall perform self-audit procedures as outlined in Station Operating Manual (SOM).

J. INTERFACING PROCEDURES

1. The publications listed below interface with this section. The PPR is required to review this content, whenever a change is proposed, to assess if an interfacing revision is needed.
 - a) CM 03-00 CASS Audit Element
 - b) GPM 03-01 Technical Publications
 - c) Station Operating Manual (SOM)

END

FUEL QUALITY CONTROL STANDARDS

CONTENTS

03-00.A	General	1
03-00.B	Procedures	1

A. GENERAL

1. Chapter 3 of the FSPM is intended for use at commercial airports within the 48 contiguous United States.
 - a) At locations other than those, alternate procedures may need to be developed due to local country or other regulatory requirements and will be handled as outlined in FSPM 02-01.
 - b) At locations within the 48 contiguous United States, alternate procedures to the policies and procedures in this manual which will not compromise fuel quality, safety or security may be developed per FSPM 02-01.
2. The requirements in this chapter specify product standards [Ref. FSPM 03-01] for the facilities and equipment of those organizations receiving [Ref. FSPM 03-02, FSPM 03-03], storing [Ref. FSPM 03-04] and dispensing [Ref. FSPM 03-06] fuel for use in Company aircraft:
 - a) It contains inspections to be performed at specified frequencies for:
 - 1) Fuel Storage Facility [Ref. FSPM 03-05]
 - 2) Fueling Vehicle [Ref. FSPM 03-07]
 - 3) Hydrant System Check [Ref. FSPM 03-08]
 - b) The inspections specify further testing and checks as follows:
 - 1) Clear and Bright Test [Ref. FSPM 03-09]
 - 2) White Bucket Test [Ref. FSPM 03-10]
 - 3) Membrane Filtration Test [Ref. FSPM 03-11]
 - 4) Free Water Test [Ref. FSPM 03-12]
 - 5) API Gravity Test [Ref. FSPM 03-13]
 - 6) Filter Vessel Differential Pressure [Ref. FSPM 03-14]
 - 7) Bonding Cable Continuity Check [Ref. FSPM 03-15]
 - 8) Water Defense System (Automatic Water Slug and Dump Systems) [Ref. FSPM 03-16]
 - 9) Fuel Storage Tank Inspection and Cleaning [Ref. FSPM 03-17]
 - 10) Water Separator Test (Microsep) [Ref. FSPM 03-18]
 - 11) Filter Element Replacement Criteria [Ref. FSPM 03-19]
 - c) For cleaning requirements, refer to:
 - 1) Hydrant Systems Cleaning Standards – Fuel System Piping [Ref. FSPM 03-20]
 - 2) Fuel Truck Tank Cleaning [Ref. FSPM 03-21]
3. The specified inspections and tests are to be performed by qualified vendor personnel who are responsible for ensuring that all fuel handling personnel employed are properly trained. Written records of employee training are to be maintained on file per FSPM 02-00. The specified inspections and tests may also be performed by a qualified independent agency under contract to the vendor, however, such contracted work does not relieve the vendor of their responsibilities as contained in this manual [Ref. FSPM 02-00].

B. PROCEDURES

1. If visible contamination is found while performing any of the above inspections, checks, tests, or at any time, fueling must be discontinued from that source. Fueling is not to be resumed from that source until the reason for contamination is found and removed.
2. The vendor shall notify the Company MSC Department in writing using one of the following:
 - a) Fax – (972) 374-9215
 - b) Email – msc.support@aa.com
 - 1) When product does not conform to ASTM D-1655.

- 2) Prior to the planned use of new fuel storage facility at new or existing stations, and prior to the planned or actual modification of existing fuel storage facilities at existing stations [Ref. FSPM 03-04].
- 3) Prior to the planned use of a new fuel vehicle at new or existing stations, and prior to the planned or actual modification of existing fuel vehicle (that affects the servicing of Envoy aircraft) at existing stations [Ref. FSPM 03-06].
- 4) Before a new, modified or repaired hydrant fuel system, or portion thereof, is placed into service [Ref. FSPM 03-19].

NOTE

The Company may elect to inspect and approve equipment and facilities for use prior to fueling aircraft.

3. The vendor shall notify the Envoy Station General Manager any time either of the following events occur:
 - a) Contaminated fuel is detected, including procedures which will be used for quarantine and disposition of contaminated fuel.
 - b) If a fueling system becomes inoperable and disrupts, or could disrupt, the Company's normal operations.

NOTE

If the local Envoy Station General Manager cannot be contacted directly, the vendor shall contact System Operations Control (SOC) at (972) 374-9400 or fax (972) 374-9197 to provide this information. SOC shall contact the DMSC to assist in resolving the issues.

4. When notified per paragraph 2 or 3 above, the DMSC is responsible for evaluating the condition, making the decision as to how a particular problem is to be resolved and responding in writing with the required actions.
5. Records, equipment and facilities of fuel storage and Into-Plane vendors are to be available for inspection by the Company during normal working hours.
 - a) Records
 - 1) Inspection records must be signed and retained for 24 months, and locally for at least 12 months. This does not apply to the Fuel Storage Tank (facility) Inspection and Cleaning Record (AE-FSPM-0317) which must be retained indefinitely.

NOTE

If current vendor has not been providing service for the previous two years, ensure these records are current from date this vendor began providing service. Ensure that next due dates for filter changes, periodic checks, etc., have been properly established.

- 2) The forms listed in this section are equal in format to ATA Specification 103 which promotes industry standardization. Copies may be made of the forms in this manual, as necessary.
- 3) Vendors are not required to use the inspection/check forms listed in this manual, however they must document the required checks in a manner that meets or exceeds the applicable forms in this manual.
- b) Signature Requirements
 - 1) The legible signature, initials or employee identification number is required of the person performing the task or the person accepting responsibility for the performance of the task.
 - 2) If initials or employee identification numbers are used, a record of each persons name and initial/identification number must be maintained and available for review.
 - 3) If another person has signed a form accepting responsibility for accomplishment of a task, supporting documentation with the signature, initial or identification number of the person actually performing the task must be available.
6. Vendors are to have documented procedures for:
 - a) Flushing new, modified or repaired hydrant systems [Ref. FSPM 03-20].
 - b) Reporting any observed deficiencies or safety hazards by its employees to management.
 - c) Tool Calibration Program:
 - 1) The Tool Calibration program should include but not be limited to a master pressure gauge, Volt-Ohm meter and a torque wrench.

Fueling and Servicing Procedures Manual

03-00
Page 3 of 3
07 Jan 15

-
- 2) The Tool Calibration program shall identify by title the person who is responsible for ensuring that calibrated tools are maintained and stored properly.
 - 3) Fuel vendors shall also identify the calibration interval of each tool and maintain on file documentation of calibration.
7. Sump Fuel
- a) Sump fuel shall not be used for aviation purposes unless the storage facility is equipped with a closed Reclaim and Filtration System.
 - b) If the facility does not have a Reclaim System, the vendor is to dispose of sump fuel in accordance with applicable local, state and federal regulations.
8. Disposition of fuel that is defueled from Envoy aircraft
- a) Fuel removed from an aircraft for purposes other than contamination shall be returned to Envoy Air Inc.
 - b) This fuel must not be delivered to another Company or person without Envoy's approval.

END

Fueling and Servicing Procedures Manual

PRODUCT STANDARDS FOR JET FUEL RECEIVED, STORED AND DISPENSED TO THE COMPANY

CONTENTS

03-01.A	General	1
03-01.B	Specification Requirements	1

TABLES

Table FSPM 03-01.a	Fuel Quality Criteria	2
--------------------	-----------------------	---

A. GENERAL

1. Jet fuel received, stored and dispensed to the Company is to meet the specification requirements in this section.
2. In the event the limits are reached or exceeded during receiving, the vendor is to:
 - a) Discontinue fuel transfer or receipt and initiate an immediate investigation to determine if there is fuel contamination or a specification problem.
 - b) Notify the local Envoy Station General Manager, who shall contact the Director Maintenance Safety and Compliance (DMSC) to assist in resolving the issues.

NOTE

If the local Envoy Station General Manager cannot be contacted directly, the vendor shall contact System Operations Control (SOC) at (972) 374-9400 or fax (972) 374-9197 to provide this information. SOC shall contact DMSC to assist in resolving the issues.

3. Jet fuel is to conform to ASTM specification D-1655, latest revision, and is to be of the Aviation Kerosene type, Jet A or Jet A-1.

B. SPECIFICATION REQUIREMENTS

1. Color Membrane
 - a) Detects particulate matter in jet fuel and it is particularly useful in monitoring the cleanliness of fuel received and in evaluating the performance of filter vessels [Ref. FSPM 03-11].
2. Visual Assessment Rating
 - a) Jet A normally ranges in appearance from no color to a definite light straw or amber color. A straw-colored product or a product having no color can both be clear and bright as defined.
 - b) In all phases of fuel handling the appearance of jet fuel shall be visually free of undissolved water, sediment and suspended matter [Ref. FSPM 03-10].
3. Gravimetric
 - a) API gravity must be from 37 through 51 API units, corrected to 60°F per FSPM 03-13.
 - b) Fuel is unacceptable and must be **rejected** if API gravity, corrected to 60°F, is not between 37 and 51 units, or if there is a sudden change in API gravity of one unit or more from the same source or supplier.
4. Free Water Test
 - a) Free water exists as a separate liquid in fuel, is heavier than fuel and will settle to the bottom of tanks and accumulate in low points in Fuel Systems.
 - b) Free water can cause various problems and is not permitted to accumulate or remain in Fuel Systems [Ref. FSPM 03-12].

CONTINUED ON FOLLOWING PAGE

Fueling and Servicing Procedures Manual

03-01
Page 2 of 2
02 Sep 14

5. The criteria listed in the table below are established for fuel quality using the tests referenced above. Exceeding the criteria requires further investigation, but are not to be used as rejection criteria.

Table FSPM 0301.a: Fuel Quality Criteria

TEST	FUEL RECEIVED INTO STORAGE (1)	FUEL DISPENSED FROM STORAGE (2)	FUEL DISPENSED INTO AIRCRAFT (2)
Color Membrane ASTM D-3830 (Max)	A3, B3 or G3 1 gallon Dry Rating (Max)	A2, B2 or G2 1 gallon Dry Rating (Max)	A2, B2 or G2 1 gallon Dry Rating (Max)
Visual Assessment Rating	B Maximum	N/A	N/A
Gravimetric ASTM D-2276	1 mg./US Gallon (Max)	N/A	N/A
Free Water Test	30 PPM (Max)	15 PPM (Max)	15 PPM (Max)
(1) Upstream of Filtration (2) Downstream of Filtration			

END

Fueling and Servicing Procedures Manual

FUEL ACCEPTANCE BY PIPELINE AND MARINE VESSELS

CONTENTS

03-02.A	General	1
03-02.B	Pipeline Deliveries	1
03-02.C	Pipeline Record of Receipt	2

TABLES

Table FSPM 03-02.a	Instructions for Completing AE-FSPM-0302 Pipeline Record of Receipt	2
Table FSPM 03-02.b	AE-FSPM-0302 Pipeline Record of Receipt	4

A. GENERAL

1. The following requirements should be established as the minimum standard for facilities receiving fuel by pipeline and marine vessels.

NOTE

Particulates at storage facilities where fuel is received directly into a designated receiving tank via pipeline, may exceed the maximum allowable particulate rating, provided the recommended settling time is allowed and fuel is then filtered prior to being placed into designated storage tanks.

B. PIPELINE DELIVERIES

CAUTION

The facility must not be left unattended at any time during the delivery.

1. Prior to Delivery:
 - a) Obtain a shipping document from jet fuel supplier or shipping agent that certifies product as meeting all ASTM D1655 specification requirements. Shipping document is to include the following information:
 - 1) Destination
 - 2) Batch number
 - 3) Fuel grade or type
 - 4) Quantity to be shipped
 - b) Prior to delivery, prepare receiving tank and facility (e.g., gauging, sumping, correct positioning of inlet/outlet valves, etc.).
 - c) Coordinate communications between pipeline shipping and facility receiving personnel to ensure applicable documentation, notifications and procedures are in place to ensure satisfactory fuel receipt.
2. During Delivery:
 - a) Fuel receiving process must be monitored at all times by airport facility personnel.

CAUTION

It is not acceptable to receive and dispense fuel from the same tank simultaneously.

- b) At the beginning, midpoint, and near end of fuel receipt, the facility operator is to conduct the following tests after inbound filtration and record the results:

NOTE

If fuel fails any of the following tests, product in receiving tanks must be quarantined pending further investigation and applicable corrective actions. The Company must be notified per FSMP 03-00 if fueling system becomes inoperable due to contamination and disrupts or may disrupt the Company's operation.

[Ref. FSPM 03-00]

- 1) Visual appearance in white bucket [Ref. FSPM 03-10].
- 2) API gravity (corrected to 60°F) [Ref. FSPM 03-13]. For fuel receipt of less than four hours only a beginning and near end test is needed. Fuel is unacceptable and must be REJECTED if API gravity, corrected to 60°F, is not between 37° and 51° API (.8398 and .7753 specific gravity) and/or Flash point is less than 100°F. Discontinue fuel transfer or receipt and initiate an immediate investigation to determine if there is fuel contamination or a specification problem if there is a change of more than 1° API or 5°F in flash point from source as shown on shipping document.

Fueling and Servicing Procedures Manual

- 3) Membrane Filtration Test [Ref. FSPM 03-11].
- 4) Free Water Test [Ref. FSPM 03-12].
- 5) Flash point (Multi-Product Pipeline Deliveries only).

CAUTION

*Pipeline volumes between shipping tanks and sampling points may be from a previous batch.
Fuel test shall be timed to coincide with actual arrival of product from shipping tank.*

- c) Periodically monitor pressure differential of inlet filtration, tank fill levels and check system for product leaks.
3. Upon Completion of Delivery:
- a) Secure receiving tank(s) and facility items (e.g., gauging, record results of sumping tanks and filters, set inlet and outlet valves for correct positioning, etc.).

NOTE

To help improve fuel purity, it is desirable to have one hour settling per vertical foot of fuel depth.

- b) Multi-Product Pipelines

Upon completion of jet fuel delivery via a Multi-Product pipeline, the facility operator is to immediately conduct ASTM D1655 property test for comparison to shipping documents and for meeting specification requirements prior to releasing the tank for aircraft use. Full ASTM D1655 specification testing is required if any of the test properties exceeds the maximum allowable difference from the shipping documents. **FUEL NOT MEETING ASTM D1655 SPECIFICATION IS TO BE REJECTED.**

NOTE

Pipelines are considered “dedicated” only if they do not have inlet connections to any other product from the last tank or point the fuel was completely re-certified as jet fuel meeting ASTM D1655 specifications. There is a significant increase in exposure to fuel contamination problems when airports receive jet fuel by “Multi-Product” pipelines as compared to “dedicated” pipelines. Additional care must be taken to prevent the fuel specification values from being impacted.

C. PIPELINE RECORD OF RECEIPT

1. The Pipeline Record of Receipt (AE-FSPM-0302) is to be used by vendor for acceptance of fuel delivery.

Table FSPM 0302.a: Instructions for Completing AE-FSPM-0302 Pipeline Record of Receipt

ITEM	DESCRIPTION	
a)	Enter vendor's name.	Vendor
b)	Enter airport three letter code.	Vendor
c)	Enter date of receipt.	Vendor
d)	Enter city.	Vendor
e)	Enter receipt number.	Vendor
f)	Enter tank designated to receive fuel.	Vendor
g)	Enter tank volume.	Vendor
h)	Enter if satisfactory or unsatisfactory.	Vendor
i)	Enter if satisfactory or unsatisfactory after the product delivery has been confirmed with pipeline.	Vendor
j)	Enter API Gravity, corrected to 60°F.	Vendor
k)	Enter observed API gravity.	Vendor
l)	Enter observed fuel temperature (°F).	Vendor

Fueling and Servicing Procedures Manual

Table FSPM 0302.a: Instructions for Completing AE-FSPM-0302 Pipeline Record of Receipt

ITEM	DESCRIPTION	
m)	Enter filter unit number.	Vendor
n)	Enter differential pressure in psi.	Vendor
o)	Enter tank volume.	Vendor
p)	Signature of person receiving and performing checks.	Vendor
q)	Enter any remarks.	Vendor

2. Disposition

- a) Retain this form for 24 months.
- b) Completed forms must be available for review by the Company.

CONTINUED ON FOLLOWING PAGE

Fueling and Servicing Procedures Manual

Table FSPM 0302.b: AE-FSPM-0302 Pipeline Record of Receipt

AE-FSPM-0302
04 May 10

PIPELINE RECORD OF RECEIPT

VENDOR (a)	AIRPORT CODE (b)			DATE (c)		
CITY (d)	RECEIPT NO. (e)			RECEIPT NO. (e)		
REQUIRED CHECKS	FRONT	MIDDLE	END	FRONT	MIDDLE	END
PRIOR TO RECEIPT						
DESIGNATE AND SUMP RECEIVING TANK	(f)					
GAUGE AND RECORD TANK VOLUME	(g)					
SET VALVES FOR RECEIVING	(h)					
PIPELINE COORDINATION						
CORRECT DESTINATION	(i)					
CORRECT GRADE OF FUEL	(i)					
CORRECT VOLUME OF FUEL	(i)					
DURING RECEIPT						
APPEARANCE	(h)					
API GRAVITY. CORRECTED TO 60°F	(j)					
OBSERVED API GRAVITY	(k)					
FUEL TEMP - °F OBSERVED	(l)					
MEMBRANE FILTRATION TEST	(h)					
WATER TEST	(h)					
SYSTEM LEAKS	(h)					
DIFFERENTIAL PRESS. REC. (psi) UNIT No.	(m)	(n)				
AFTER RECEIPT						
RE-POSITION VALVES			(h)			
GAUGE AND RECORD TANK VOLUME (GAL)			(o)			
WHITE BUCKET TEST - TANK SUMP			(h)			
WHITE BUCKET TEST - FILTER SUMPS			(h)			

SIGNATURE OF PERSON PERFORMING CHECKS	(p)					
✓ SATISFACTORY X - UNSATISFACTORY		ENTER REMARKS				
(q)						

RETAIN FOR 24 MONTHS

END

FUEL ACCEPTANCE BY TRANSPORT TRUCK AND RAIL CAR

CONTENTS

03-03.A	General	1
03-03.B	Transport Truck Deliveries	1
03-03.C	Transport Truck Record of Receipt	2

TABLES

Table FSPM 03-03.a	Instructions for Completing AE-FSPM-0303 Transport Truck Record of Receipt	2
Table FSPM 03-03.b	AE-FSPM-0303 Transport Truck Record of Receipt	3
Table FSPM 03-03.c	Example of AE-FSPM-0303 With Entries	4

A. GENERAL

1. The following requirements shall be established as the minimum standard for facilities receiving fuel by transport truck and rail car.

B. TRANSPORT TRUCK DELIVERIES

1. Prior to Delivery:
 - a) Initiate Transport Truck Record of Receipt (AE-FSPM-0303) ([p 3](#)) for use, reference and completion during delivery.
 - b) Receiving tank should be gauged prior to delivery to verify there is sufficient room in the tank to hold the fuel.

CAUTION

During the fuel delivery, the equipment must not be left unattended at any time. The transport truck driver must remain with the vehicle at all times.

- c) Prepare receiving tank(s) and facility prior to delivery (e.g., gauging, sumping, correct positioning of inlet/outlet valves, etc.).
- d) Obtain a shipping document from jet fuel supplier or shipping agent certifying product being delivered to airport meets all ASTM D1655 specification requirements with at least the following select property values listed as measured in specified ASTM test methods. Shipping documents include the following delivery information:
 - 1) Destination
 - 2) Batch number
 - 3) Fuel grade or type
 - 4) Quantity to be shipped
 - 5) API Gravity - Corrected to 60°F
- e) Allow truck to set for a minimum of 10 minutes with the tank internal valves open.
- f) Conduct and record the results of the following tests:

NOTE

If fuel fails any of the following tests, product in receiving tanks must be quarantined pending further investigation and applicable corrective actions. The Company must be notified per FSPM 03-00 if fueling system becomes inoperable due to contamination and disrupts or may disrupt the Company's operation [Ref. FSPM 03-00].

- 1) Visual Appearance in White Bucket [Ref. FSPM 03-10]. Use extreme care and vigilance when performing test. Slight traces of water, solids or color may indicate the presence of product mixes or other contaminants that could cause jet fuel to be off-specification and unacceptable for aircraft use. Any unusual results must be investigated. If visible contaminants are observed in white bucket, more than one sumping may be required to clear it. If contaminants remain after approximately three five gallon individual samples from one tank truck compartment, the load must be rejected. A representative sample of the rejected product, including supporting documentation, should be retained in a clean container for future reference.
- 2) API Gravity – Corrected to 60°F [Ref. FSPM 03-13]. Fuel is unacceptable and must be rejected if API Gravity, corrected to 60°F, is not between 37° and 51°F API (.8398 and .7753 specific gravity). Discontinue fuel transfer or receipt and initiate an immediate investigation to determine if there is fuel contamination or a specification problem if there is a change of more than 1° API from source as shown on shipping document.

- g) Coordinate communications between transport truck driver and facility receiving personnel to ensure applicable documentation, notifications and procedures are in place to ensure satisfactory fuel receipt. Prior to connecting truck discharge hoses to airport facility receiving connections, ensure truck unloading hoses and fittings are inspected for deficiencies, pending failures and cleanliness.
- 2. During Delivery:
 - a) While receiving fuel into airport storage, facility operator is to periodically monitor pressure differential of inlet filtration and check system for product leaks.
- 3. Upon Completion of Delivery:
 - a) Secure receiving tank(s) and facility items, (e.g., gauging, record results of sumping tanks and filters, set inlet and outlet valves for correct positioning, etc.).
 - b) Record tank and filter sump results. Records are to be retained for 24 months, 12 months locally.
 - c) Ensure Transport Truck Record of Receipt has been completed. Retain per sub-paragraph "Disposition."

C. TRANSPORT TRUCK RECORD OF RECEIPT

- 1. Transport Truck Record of Receipt (AE-FSPM-0303) is to be used by vendor for acceptance of fuel delivery.

Table FSPM 0303.a: Instructions for Completing AE-FSPM-0303 Transport Truck Record of Receipt

ITEM	DESCRIPTION	RESPONSIBILITY
a)	Enter vendor's name.	Vendor
b)	Enter airport three letter code.	Vendor
c)	Enter date of receipt.	Vendor
d)	Enter city.	Vendor
e)	Enter tank designated to receive fuel.	Vendor
f)	Enter tank volume in gallons.	Vendor
g)	Enter if satisfactory or unsatisfactory.	Vendor
h)	Enter document number.	Vendor
i)	Enter volume of fuel in gallons.	Vendor
j)	Enter API Gravity, corrected to 60°F.	Vendor
k)	Enter observed fuel temperature (°F).	Vendor
l)	Enter differential pressure in psi.	Vendor
m)	Enter tank volume in gallons.	Vendor
n)	Signature of person receiving and performing checks.	Vendor
o)	Enter any remarks.	Vendor

- 2. Disposition
 - a) Retain this form for 24 months.
 - b) Completed forms must be available for review by the Company.

CONTINUED ON FOLLOWING PAGE

Fueling and Servicing Procedures Manual

Table FSPM 0303.b: AE-FSPM-0303 Transport Truck Record of Receipt

AE-FSPM-0303
04 May 10

JET FUEL STORAGE FACILITY TRANSPORT TRUCK RECORD OF RECEIPT

VENDOR (a)	AIRPORT CODE (b)				DATE (c)	
CITY (d)	RECEIPT NUMBER					
REQUIRED CHECKS	1	2	3	4	5	6
PRIOR TO RECEIPT						
DESIGNATE AND SUMP RECEIVING TANK	(e)					
GAUGE AND RECORD TANK VOLUME	(f)					
SET VALVES FOR RECEIVING	(g)					
CHECK CONDITION OF OFF LOAD HOSE	(g)					
CONNECT BONDING CABLE	(g)					
BILL OF LADING						
DOCUMENT NUMBER	(h)					
CORRECT DESTINATION	(g)					
CORRECT GRADE OF FUEL	(g)					
CORRECT VOLUME OF FUEL	(i)					
TRANSPORT TRUCK						
CHECK COMPARTMENT SEALS	(g)					
CLEAR AND BRIGHT TEST	(g)					
API GRAVITY, CORRECTED TO 60°F	(j)					
FUEL TEMP - °F OBSERVED	(k)					
DURING RECEIPT						
DIFFERENTIAL PRESS. REC. (psi)	(l)					
SYSTEM FOR LEAKS	(g)					
AFTER RECEIPT						
DISCONNECT AND STOW HOSE	(g)					
DISCONNECT BONDING CABLE	(g)					
GAUGE AND RECORD TANK VOLUME (GAL)	(m)					
WHITE BUCKET TEST - TANK SUMP	(g)					
WHITE BUCKET TEST - FILTER SUMPS	(g)					

SIGNATURE OF PERSON PERFORMING CHECKS	(n)					
---------------------------------------	-----	--	--	--	--	--

✓ SATISFACTORY X - UNSATISFACTORY

ENTER REMARKS

(o)

RETAIN FOR 24 MONTHS

Fueling and Servicing Procedures Manual

3. Example of Form with Entries:

Table FSPM 0303.c: Example of AE-FSPM-0303 With Entries

AE-FSPM-0303
04 May 10

JET FUEL STORAGE FACILITY TRANSPORT TRUCK RECORD OF RECEIPT

VENDOR <i>XYZ Aviation, Inc.</i>	AIRPORT CODE <i>CLT</i>			DATE <i>3/12/01</i>		
CITY <i>Charlotte</i>	RECEIPT NUMBER					
REQUIRED CHECKS	1	2	3	4	5	6
PRIOR TO RECEIPT						
DESIGNATE AND SUMP RECEIVING TANK	<i>No. 3</i>					
GAUGE AND RECORD TANK VOLUME	<i>2,000</i>					
SET VALVES FOR RECEIVING	✓					
CHECK CONDITION OF OFF LOAD HOSE	✓					
CONNECT BONDING CABLE	✓					
BILL OF LADING						
DOCUMENT NUMBER	<i>1347</i>					
CORRECT DESTINATION	✓					
CORRECT GRADE OF FUEL	✓					
CORRECT VOLUME OF FUEL	<i>8,000</i>					
TRANSPORT TRUCK						
CHECK COMPARTMENT SEALS	<i>N/A</i>					
CLEAR AND BRIGHT TEST	✓					
API GRAVITY, CORRECTED TO 60°F	<i>43.0</i>					
FUEL TEMP - °F OBSERVED	<i>75</i>					
DURING RECEIPT						
DIFFERENTIAL PRESS. REC. (psi)	<i>2</i>					
SYSTEM FOR LEAKS	✓					
AFTER RECEIPT						
DISCONNECT AND STOW HOSE	✓					
DISCONNECT BONDING CABLE	✓					
GAUGE AND RECORD TANK VOLUME (GAL)	<i>10,000</i>					
WHITE BUCKET TEST- TANK SUMP	✓					
WHITE BUCKET TEST - FILTER SUMPS	✓					

SIGNATURE OF PERSON PERFORMING CHECKS	<i>A. E. Newman</i>					
---------------------------------------	---------------------	--	--	--	--	--

✓ SATISFACTORY X - UNSATISFACTORY ENTER REMARKS

15 gallons of waste material drained from tanker before serviceable product obtained.

RETAIN FOR 24 MONTHS

END

FUEL STORAGE FACILITY REQUIREMENTS

CONTENTS

03-04.A	General	1
03-04.B	Facility Requirements	1

A. GENERAL

1. All storage facilities, tanks and equipment used to contain and dispense fuel used in the Company's aircraft must meet the requirements in this section.
2. Vendors with existing facilities which do not meet requirements of this section are to submit a request for Alternate Procedures per FSPM 02-01 [Ref. FSPM 02-01].
3. The vendor shall notify the Company in writing prior to using new or modified equipment per FSPM 03-00.

B. FACILITY REQUIREMENTS

1. Storage Areas
 - a) In accordance with 14 CFR Part 139, Certification of Airports, fuel storage areas are to be fenced and placarded with DANGER-FLAMMABLE and other warning signs to discourage unauthorized entry [Ref. 14 CFR Part 139].
 - b) NO SMOKING, FLAMMABLE, EMERGENCY SHUTOFF and other informational signs must be displayed in accordance with local governing codes.
 - c) The fuel storage facility must be properly color coded in accordance with API Standard 1542 (latest edition).
 - d) Fire extinguishers with inspection tags must be positioned in accordance with local requirements.
 - e) The general condition of the yard area shall be clean in appearance. Report and correct any condition that needs immediate attention (e.g., plugged drainage, weeds, poor housekeeping, etc.). Evidence of any recent fuel spill must be investigated and corrected immediately.
 - f) Where more than one grade of fuel is stored in a fuel storage area, physically segregated systems are required to prevent accidental mixing of products. Use of isolation valves or blind flanges are not acceptable methods of product grade separation.
 - g) All Electrical Systems must meet the governing codes and ordinances.
2. Filter/Separators
 - a) Filter/Separators or full flow monitors are required for receiving fuel into and dispensing fuel from storage tanks that will supply fuel directly into aircraft, refuelers or hydrant systems. If only one is available, it must be installed to perform both fuel receiving and dispensing functions.

NOTE

Existing full-flow monitors at fuel facilities must be replaced within 1 year from the date of ATA 103 revision 2009.1.

CAUTION

Full-flow monitors must not be used with fuels containing Fuel System Icing Inhibitors (FSII). The water removal performance of full-flow monitors may be reduced by fuel containing FSII.

- b) Filter/Separator elements must meet the requirements of API/PI 1581, Group II, Class B, latest edition or be qualified by similarity as defined in Appendix A. If qualified by similarity, a qualification report must be maintained locally and a data plate reflecting such qualification must be attached to the vessel.
- c) All filter vessels must be equipped with:
 - 1) Provisions for elimination of air, direct reading differential pressure gauges, manual sump drains (valves with handles spring loaded to the closed position are recommended), upstream and downstream sampling (Millipore) connections including probes and dust caps or plugs, pressure relief valves.
 - 2) Placard indicating month and year of last filter change.
 - 3) Automatic Water Defense Systems which will stop fuel flow or alert operating personnel when actuated by a high water level. Float or Electronic Probe Systems must include provisions for an operational test.
 - 4) Name plate with required information (API/PI 1581).
 - 5) Placard indicating sump drain and location.

Fueling and Servicing Procedures Manual

3. Valves, Hoses, Nozzles, Connections, etc.
 - a) Relaxation chambers, where installed, shall be equipped with:
 - 1) Air eliminator, pressure relief valve
 - 2) Manual sump drain (Valves with handles spring loaded to the closed position are recommended.)
 - b) Connections for receiving and dispensing different grades of fuel must be physically incompatible.
 - c) Fuel flow emergency shut-off valves and switches must be clearly marked in accordance with NFPA 407 as revised, and the area around them must be kept free of obstructions.
 - d) Bottom loading nozzles/couplers must be equipped with 60 mesh or finer screens.
 - e) All fueling hoses must meet API 1529, Type C or BSI 3158, Type C standards. Fuel unloading hoses should be compatible with jet fuel and suitable for local conditions.
 - f) A deadman control device is required for all truck loading operations.
 - g) Static bonding connections must be provided between truck and fill stand at all truck loading points.

4. Tanks

- a) Design and construction of fuel storage tanks must comply with governing codes and ordinances.

CAUTION

Galvanized materials must not be used in Jet Fuel Service, no copper alloys, cadmium plating or plastic materials are permitted for main fuel piping. The use of copper or copper alloy materials for other components must be minimized.

- b) All storage tanks are to include the following equipment:
 - 1) Floating suction with means of verifying proper operation, or a stand pipe
 - 2) Inlet diffuser
 - 3) Gauge hatch with slotted tube
 - 4) Access manway (two are preferred, should have CONFINED SPACE access placards)
 - 5) Automatic high liquid level device(s) to prevent tank overflow
- c) Metal underground tanks and piping should be cathodically protected.
- d) Placard indicating the volume of tank drain piping shall be placed adjacent to tank drain devices.
- e) Above Ground Vertical Tanks

In addition to the items in paragraph "Facility Requirements, Tanks," above ground vertical tanks must include the following:

- 1) Light color epoxy coated floor.
- 2) Sides up to the top of the first wall panel – Complete internal coating is recommended, cone down bottom to positive center sump with drain.
- 3) Non-metallic tanks are not acceptable.

- f) Above Ground Horizontal Tanks

In addition to the items in paragraph "Facility Requirements, Tanks," above ground horizontal tanks must include the following:

- 1) Carbon steel tanks must have complete internal light colored epoxy coating.
- 2) Sloped bottom to positive sump with drain.
- 3) Non-metallic tanks are not acceptable, access manways should be equipped with an internal ladder.

- g) Underground Tanks

In addition to the items in paragraph "Facility Requirements, Tanks," underground tanks must include the following:

- 1) Carbon steel must have complete internal light colored epoxy coating.
- 2) Access manways should be equipped with an internal ladder.
- 3) Manways and other tank appurtenances must be extended above ground where possible.
- 4) Sloped bottom to positive sump with permanent pump.

END

FUEL STORAGE FACILITY INSPECTIONS

CONTENTS

03-05.A	General	1
03-05.B	Daily Inspections	1
03-05.C	Monthly Inspections	2
03-05.D	Fuel Quality Test Record	3
03-05.E	Daily Fuel Facility Checklist	5
03-05.F	Daily/Monthly Fuel Facility Checklist	7
03-05.G	Quarterly Inspections	9
03-05.H	Semi-Annual Inspections	9
03-05.I	Annual Inspections	9
03-05.J	Quarterly/Semi-Annual Fuel Facility Checklist	10
03-05.K	Annual Fuel Facility Checklist	10

TABLES

Table FSPM 03-05.a	Instructions for Completing AE-FSPM-0305 Fuel Quality Test Record	3
Table FSPM 03-05.b	AE-FSPM-0305 Fuel Quality Test Record	4
Table FSPM 03-05.c	Instructions for Completing AE-FSPM-0305.1 Daily Fuel Facility Checklist	5
Table FSPM 03-05.d	AE-FSPM-0305.1 Daily Fuel Facility Checklist	6
Table FSPM 03-05.e	Instructions for Completing AE-FSPM-0305.2 Daily/Monthly Fuel Facility Checklist	7
Table FSPM 03-05.f	AE-FSPM-0305.2 Daily/Monthly Fuel Facility Checklist	8
Table FSPM 03-05.g	Instructions for Completing AE-FSPM-0305.3 Quarterly/Semi-Annual Fuel Facility Checklist	10
Table FSPM 03-05.h	Instructions for Completing AE-FSPM-0305.4 Annual Fuel Facility Checklist	10
Table FSPM 03-05.i	AE-FSPM-0305.3 Quarterly/Semi-Annual Fuel Facility Checklist	11
Table FSPM 03-05.j	AE-FSPM-0305.4 Annual Fuel Facility Checklist	12

A. GENERAL

1. Daily, Monthly, Quarterly and Annual checks/inspections must be performed on all fuel storage facilities servicing Company aircraft and at the frequencies specified.

NOTE

Records, paper or electronic, must be completed by the person performing the tasks, or by the person accepting responsibility for performance of the tasks as referenced in FSPM 03-00 Fuel Quality Control Standards [Ref. FSPM 03-00].

2. Additional tasks such as those contained in Alternate Procedures, or more frequent checks may be required based on local conditions.
3. Record inspections and initial rating on the appropriate Company form. Other forms may be used per FSPM 03-00 if they meet or exceed the inspection and frequency requirements contained in this section [Ref. FSPM 03-00].

B. DAILY INSPECTIONS

A daily inspection shall be performed, including weekends/holidays, and recorded on the Daily Fuel Facility Checklist (AE-FSPM-0305.1) (p 6), the Daily/Monthly Fuel Facility Checklist (AE-FSPM-0305.2) (p 8) and additional forms as indicated for each item. The following items are included as daily inspection items:

1. **General Condition of Tank Yard** – Check the general condition of the yard area for appearance and cleanliness. Report and correct any condition that needs immediate attention, e.g., plugged drainage, weeds, poor housekeeping, etc. Check tanks, piping, valves, hoses, meters, filters and other fuel handling equipment for leaks. Any visible leaks must be immediately reported and repaired. Evidence of any recent fuel spill must be investigated immediately. Check for the safe condition of stairways, handrails, ladders, walking surfaces and adequacy of area and access lighting in tank yard and on above ground tanks. Note any electrical deficiencies that are obvious safety and fire hazards. Note any unusual sounds or noises from pumps, motors, meters, control valves and other mechanical devices that might indicate pending failure. Also, check condition of exterior paint covering facilities and equipment for protection and appearance. Record rating on Daily/Monthly Fuel Facility Checklist (AE-FSPM-0305.2) (p 8).
2. **Security, Fire and Safety Deficiencies** – Check fuel storage facilities for any security, fire or safety deficiencies or unusual conditions requiring immediate correction. Where applicable, ensure that any broken fences or gates are repaired or replaced immediately. All gate and access doors must be kept locked in unsecured areas, loading/unloading hoses, master electrical switches and other accessible fittings must be kept locked at all times when not in use. Record rating on Daily/Monthly Fuel Facility Checklist (AE-FSPM-0305.2) (p 8).

3. **Hoses, Swivels and Nozzles** – Check condition of all fuel hoses, swivels and nozzles for wear, damage and leakage. Check hoses for abrasions, cuts, soft spots, carcass separation, worn covers, blisters, exposed reinforcement, cracks, twists and sharp bends that give the appearance of pending failure. Check tightness of all swivel attachment screws and hose couplings. Check condition of nose and poppet seals on nozzles for cuts, nicks and wear. Any item that is defective or is leaking must be replaced or repaired immediately. Dust covers or other protective devices must be used to prevent debris from accumulating on mating surfaces of fuel nozzles. Record rating on Daily/Monthly Fuel Facility Checklist (AE-FSPM-0305.2) ([p 8](#)).
4. **Bonding Reels, Cables and Clamps** – Check condition of static bonding reels, cables and clamps. Defective equipment should be repaired or replaced immediately. Record rating on Daily/Monthly Fuel Facility Checklist (AE-FSPM-0305.2) ([p 8](#)).
5. **Fire Extinguishers** – Verify that fire extinguishers are in proper place with unobstructed access for immediate use. If seal is broken or inspection tag is missing, extinguisher must be taken out of service until recharged and tagged for acceptance. Record rating on Daily/Monthly Fuel Facility Checklist (AE-FSPM-0305.2) ([p 8](#)).
6. **Storage Tank and Product Reclamation Tank Sumps** – Perform white bucket test of all sump drains on working tanks and product reclamation tanks (if installed) per FSPM 03-10. Record first sample findings on Daily Fuel Facility Checklist (AE-FSPM-0305.1) ([p 6](#)) [Ref. FSPM 03-10].
7. **Filter Sumps** – Perform white bucket test of all working filter sump drains per FSPM 03-10. Record first sample findings on Daily Fuel Facility Checklist (AE-FSPM-0305.1) ([p 6](#)) [Ref. FSPM 03-10].
8. **Filter Differential Pressure** – Under steady flow conditions, check and record observed differential pressure across all working filters. Record findings on Daily Fuel Facility Checklist (AE-FSPM-0305.1) ([p 6](#)) or equivalent and if desired, plot on Fuel Filter Vessel Record (AE-FSPM-0314) or equivalent.

C. MONTHLY INSPECTIONS

A monthly inspection shall be performed with all ratings recorded on the Daily/Monthly Fuel Facility Checklist (AE-FSPM-0305.2) ([p 8](#)) and additional forms as indicated. This inspection requires the following:

1. **Filtration Test** – Perform a Membrane Filtration Test [Ref. FSPM 03-11], Free Water Test [Ref. FSPM 03-12] to 15 PPM downstream of filter. Record findings on Fuel Quality Test Record (AE-FSPM-0305) ([p 4](#)).
2. **Bonding Cable Continuity** – Perform electrical continuity check on bonding cables and clamps [Ref. FSPM 03-15].
3. **Nozzle Screens** – Remove nozzles and examine screens for particles. If particles are found, investigate sources of contamination which could be from inner hose lining, pipe rust, sand, low point sediment, equipment failure, seals, gaskets, etc. Screens are to be cleaned or replaced if damaged.
4. **Signs and Placards** – Verify that fueling equipment is clearly marked with the proper type of fuel being dispensed, flammable/no smoking, emergency shut-off and other appropriate information and instructions, signs or decals as required.
5. **Floating Suctions** – Verify satisfactory operation of all tank floating suction if installed.
6. **Fire Extinguisher** – Check fire extinguisher inspection tag dates, seals and verify that extinguishers are properly charged.
7. **Corrected Filter Differential Pressure** – Under steady flow conditions, check and record observed differential pressure, flow rate and corrected differential pressure across each working filter.

CONTINUED ON FOLLOWING PAGE

D. FUEL QUALITY TEST RECORD

1. Fuel Quality Test Record (AE-FSPM-0305) ([p 4](#)) is to be completed as follows:

Table FSPM 0305.a: Instructions for Completing AE-FSPM-0305 Fuel Quality Test Record

ITEM	DESCRIPTION	RESPONSIBILITY
a)	Enter airport.	See Note at A.1. (p 1)
b)	Enter facility.	See Note at A.1. (p 1)
c)	Enter vendor.	See Note at A.1. (p 1)
d)	Enter date.	See Note at A.1. (p 1)
e)	Indicate type.	See Note at A.1. (p 1)
f)	Enter differential pressure in psi.	See Note at A.1. (p 1)
g)	Enter unit number.	See Note at A.1. (p 1)
h)	Enter dry rating.	See Note at A.1. (p 1)
i)	Enter sample size in gallons.	See Note at A.1. (p 1)
j)	Enter water separation.	See Note at A.1. (p 1)
k)	Enter water in PPM.	See Note at A.1. (p 1)
l)	Enter notes as applicable.	See Note at A.1. (p 1)

2. Disposition – Retain on file for 24 months.

CONTINUED ON FOLLOWING PAGE

Fueling and Servicing Procedures Manual

Table FSPM 0305.b: AE-FSPM-0305 Fuel Quality Test Record

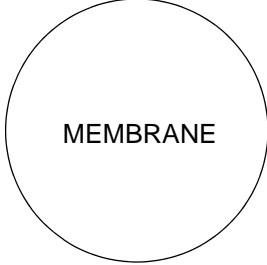
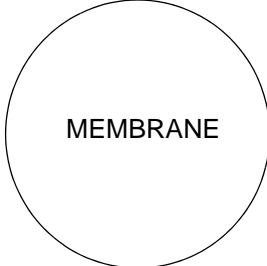
AE-FSPM-0305 03 NOV 09			
FUEL QUALITY TEST RECORD			
AIRPORT _____ (a) _____		FACILITY _____ (b) _____	
AGENCY _____ (c) _____		DATE _____ (d) _____	
SAMPLING POINT	MEMBRANE FILTRATION TEST ASTM D-2276	WATER SEPARATOR ASTM D-3948	WATER TEST
BEFORE FILTRATION () PARTICULATE () CLAY (e) () FILTER/SEPARATOR () MONITOR ELEMENT Δp _____ (f) _____ psi UNIT NO. _____ (g) _____		(j)	_____ (k) _____ ppm
DRY RATING _____ (h) _____ SAMPLE SIZE _____ (i) _____ GAL			
AFTER FILTRATION () PARTICULATE () CLAY () FILTER/SEPARATOR () MONITOR ELEMENT Δp _____ psi UNIT NO. _____			_____ ppm
DRY RATING _____ SAMPLE SIZE _____ GAL			
NOTES: _____ (l) _____			

RETAIN THIS FORM FOR 24 MONTHS			

E. DAILY FUEL FACILITY CHECKLIST

1. The Daily Fuel Facility Checklist (AE-FSPM-0305.1) ([p 6](#)) is to be completed as follows:

Table FSPM 0305.c: Instructions for Completing AE-FSPM-0305.1 Daily Fuel Facility Checklist

ITEM	DESCRIPTION	RESPONSIBILITY
a)	Enter station using three letter city code.	See Note at A.1. (p 1)
b)	Enter vendor's name.	See Note at A.1. (p 1)
c)	Enter month and year.	See Note at A.1. (p 1)
d)	Enter equipment number.	See Note at A.1. (p 1)
e)	Enter initial alpha numeric rating obtained for each item using following rating designators (e.g., 1B, 3C, etc.): 1 = Clear 2 = Slight 3 = Particulate 4 = Dirty A = Bright B = Hazy C = Cloudy D = Wet E = Surfacants	See Note at A.1. (p 1)
f)	Enter the signature of person performing tasks or person accepting responsibility that tasks were performed.	See Note at A.1. (p 1)
g)	Enter the actual differential pressure observed (e.g., 4 psi, 15 psi, etc.).	See Note at A.1. (p 1)

2. Disposition – Retain on file for 24 months.

CONTINUED ON FOLLOWING PAGE

Fueling and Servicing Procedures Manual

Table FSPM 0305.d: AE-FSPM-0305.1 Daily Fuel Facility Checklist

Daily Fuel Facility Checklist																																																													
AE-FSPM-0305.1 03 Nov 09																																																													
STORAGE TANK AND PRODUCT RECLAMATION SUMP RESULTS											STATION (a)											FACILITY (b)										MONTH (c)																													
1	2	3	4	5	6	7	8	9	10	11	12	13	14	15	16	17	18	19	20	21	22	23	24	25	26	27	28	29	30	31	1	2	3	4	5	6	7	8	9	10	11	12	13	14	15	16	17	18	19	20	21	22	23	24	25	26	27	28	29	30	31
SUMP TANKS DAILY RECORD RESULTS - SEE NOTE 1																																																													
(d)																																																													
Signature																																																													
(f)																																																													
FILTER SUMP RESULTS																																																													
1	2	3	4	5	6	7	8	9	10	11	12	13	14	15	16	17	18	19	20	21	22	23	24	25	26	27	28	29	30	31	1	2	3	4	5	6	7	8	9	10	11	12	13	14	15	16	17	18	19	20	21	22	23	24	25	26	27	28	29	30	31
SUMP FILTERS DAILY RECORD RESULTS - SEE NOTE 1																																																													
(e)																																																													
Signature																																																													
FILTER DIFFERENTIAL PRESSURE																																																													
1	2	3	4	5	6	7	8	9	10	11	12	13	14	15	16	17	18	19	20	21	22	23	24	25	26	27	28	29	30	31	1	2	3	4	5	6	7	8	9	10	11	12	13	14	15	16	17	18	19	20	21	22	23	24	25	26	27	28	29	30	31
FILTER DIFFERENTIAL PRESSURE																																																													
(g)																																																													
Signature																																																													
NOTE #1 - RATING OF SUMP SAMPLES: SOLIDS - (1) CLEAR (2) SLIGHT (3) PARTICULATE (4) DIRTY; WATER - (A) BRIGHT (B) HAZY (C) CLOUDY (D) WET (E) SURFACTANTS RETAIN ON FILE FOR 24 MONTHS																																																													

F. DAILY/MONTHLY FUEL FACILITY CHECKLIST

1. The Daily/Monthly Fuel Facility Checklist (AE-FSPM-0305.2) ([p 8](#)) is a combination daily and monthly checklist. The upper portion of the form is used to record daily check items and the lower portion is used to record monthly items. Complete the checklist as follows:

Table FSPM 0305.e: Instructions for Completing AE-FSPM-0305.2 Daily/Monthly Fuel Facility Checklist

ITEM	DESCRIPTION	RESPONSIBILITY
a)	Enter station using three letter city code.	See Note at A.1. (p 1)
b)	Enter vendor's name.	See Note at A.1. (p 1)
c)	Enter month and year.	See Note at A.1. (p 1)
d)	Enter daily rating of each item listed for each day of the month. The following rating designators are to be used: S = Satisfactory C = Comment N/U = Not Used N/A = Not Applicable	See Note at A.1. (p 1)
e)	Enter signature of person performing tasks or person accepting responsibility that tasks were performed.	See Note at A.1. (p 1)
f)	Enter monthly rating for each item. The following rating designators are to be used: S = Satisfactory C = Comment N/U = Not Used N/A = Not Applicable	See Note at A.1. (p 1)
g)	Enter date check performed.	See Note at A.1. (p 1)
h)	Enter signature of person performing tasks or person accepting responsibility that tasks were performed.	See Note at A.1. (p 1)
i)	Enter applicable remarks.	See Note at A.1. (p 1)

2. Disposition – Retain on file for 24 months.

CONTINUED ON FOLLOWING PAGE

G. QUARTERLY INSPECTIONS

A quarterly inspection shall be performed with all ratings recorded on the Quarterly/Semi-Annual Fuel Facility Checklist (AE-FSPM-0305.3) ([p 11](#)). This inspection requires the following:

1. **Emergency Shutdown System** – Operationally check the Emergency Shutdown System. Coordinate shutdown test with all persons, agents, airlines, fuel suppliers and other groups having interest in the operation of the system. Immediately report any operational discrepancies.
2. **Water Defense Systems** – Check satisfactory operation of water defense systems in accordance with quarterly requirements of FSPM 03-16 [Ref. FSPM 03-16].
3. **Tank High Level Controls** – Check satisfactory operation of tank high level sensing devices and automatic fuel flow shut-off valves where installed. Inoperative controls must be adjusted or repaired immediately or have alternate operating procedures in effect that will provide positive spill prevention while tank is in service.
4. **Product Reclamation Tank Interior Inspection** – If installed, visually inspect product reclamation tank interior for cleanliness or pass a microbiological growth test. Clean as required in accordance with FSPM 03-17 [Ref. FSPM 03-17].

H. SEMI-ANNUAL INSPECTIONS

A semi-annual inspection shall be performed twice each calendar year and recorded on the Quarterly/Semi-Annual Fuel Facility Checklist (AE-FSPM-0305.3) ([p 11](#)).

1. **Loading/Unloading hoses** – When fitted with reusable couplings and being operated under system pressure, loading/unloading hoses must undergo six-month pressure testing at 225 psi per the requirements found in API/AP 1540.

I. ANNUAL INSPECTIONS

An annual inspection shall be performed with all ratings recorded on the Annual Fuel Facility Checklist (AE-FSPM-0305.4) ([p 12](#)) and additional forms as indicated. This inspection requires the following:

1. **Storage Tank Interiors** – Open fuel storage tanks and check interiors for cleanliness and condition of coating. Clean as required and document on Storage Tank Inspection and Cleaning Record (AE-FSPM 03-17).
2. **Pressure Gauges** – Verify proper operation of filter differential pressure gauge(s) in accordance with gauge manufacturers' procedures. The differential pressure gauge lines and valves should be checked to ensure they are not plugged or restricted. Replace or repair if found defective.
3. **Filter Elements** – Replace filter elements per FSPM 03-19. Life of applicable filter elements may be extended to a maximum of two years provided the facility operator has followed criteria outlined in FSPM 03-19. Regardless of filter element replacement frequency, all filter vessels must be opened annually to visually check condition of interior for cleanliness, and integrity of elements [Ref. FSPM 03-19].
4. **Filter/Separator Heaters** – Check filter/separator sump and drain line heaters for proper operation before freezing weather where installed.
5. **Tank Vents** – Where installed, check cleanliness of tank vent screens. Tanks that have pressure/vacuum vents, check satisfactory operation and condition of poppets and inlet screens. Under freezing conditions, additional checks may be required to assure free movement of poppets.
6. **Cathodic Protection** – Where installed, confirm satisfactory operation of the cathodic protection system for underground steel storage tanks and underground piping. This requirement is generally contracted to businesses specializing in this type of service.
7. **Line Strainers** – If installed, check line strainers for cleanliness and damage. Clean or replace screens as required.
8. **Water Defense System** – Check satisfactory operation of water defense systems in accordance with annual requirements of section FSPM 03-16 [Ref. FSPM 03-16].

J. QUARTERLY/SEMI-ANNUAL FUEL FACILITY CHECKLIST

1. The Quarterly/Semi-Annual Fuel Facility Checklist (AE-FSPM-0305.3) ([p.11](#)) is to be completed each quarter as follows:

Table FSPM 0305.g: Instructions for Completing AE-FSPM-0305.3 Quarterly/Semi-Annual Fuel Facility Checklist

ITEM	DESCRIPTION	RESPONSIBILITY
a)	Enter station using three letter city code.	See Note at A.1. (p.1)
b)	Enter vendor's name.	See Note at A.1. (p.1)
c)	Enter quarter of year that checks are complied with.	See Note at A.1. (p.1)
d)	Enter year.	See Note at A.1. (p.1)
e)	Enter date of check.	See Note at A.1. (p.1)
f)	Enter rating of each item listed. The following rating designators are to be used: S = Satisfactory C = Comment, required in remarks section N/U = Not Used N/A = Not Applicable	See Note at A.1. (p.1)
g)	Enter signature of person performing check.	See Note at A.1. (p.1)
h)	Enter remarks as required.	See Note at A.1. (p.1)

2. Disposition – Retain on file for 24 months.

K. ANNUAL FUEL FACILITY CHECKLIST

1. The Annual Fuel Facility Checklist (AE-FSPM-0305.4) ([p.12](#)) is to be completed annually as follows:

Table FSPM 0305.h: Instructions for Completing AE-FSPM-0305.4 Annual Fuel Facility Checklist

ITEM	DESCRIPTION	RESPONSIBILITY
a)	Enter station using three letter city code.	See Note at A.1. (p.1)
b)	Enter vendor's name.	See Note at A.1. (p.1)
c)	Enter year.	See Note at A.1. (p.1)
d)	Enter equipment identification number for each piece of equipment.	See Note at A.1. (p.1)
e)	Enter date of check and rating of each item listed. The following rating designators are to be used: S = Satisfactory C = Comment, required in remarks section N/U = Not Used N/A = Not Applicable	See Note at A.1. (p.1)
f)	Enter signature of person performing check.	See Note at A.1. (p.1)
g)	Enter remarks as required.	See Note at A.1. (p.1)

2. Disposition – Retain on file for 24 months.

Fueling and Servicing Procedures Manual

Table FSPM 0305.j: AE-FSPM-0305.4 Annual Fuel Facility Checklist

AE-FSPM-0305.4 03 Nov 09		Annual Fuel Facility Checklist													
STATION (a)										FACILITY (b)			YEAR (c)		
		ID# (d)	ID#	ID#	ID#	ID#	ID#	ID#	ID#	ID#	ID#	ID#	ID#	ID#	ID#
1. STORAGE TANK INTERIORS	DATE AND RATING	(e)													
	CHECKED BY	(f)													
2. DIFF. PRESSURE GAUGES	DATE AND RATING	ID#	ID#	ID#	ID#	ID#	ID#	ID#	ID#	ID#	ID#	ID#	ID#	ID#	ID#
	CHECKED BY														
3. FILTER ELEMENTS	DATE AND RATING	ID#	ID#	ID#	ID#	ID#	ID#	ID#	ID#	ID#	ID#	ID#	ID#	ID#	ID#
	CHECKED BY														
4. FILTER/SEPARATOR HEATERS	DATE AND RATING	ID#	ID#	ID#	ID#	ID#	ID#	ID#	ID#	ID#	ID#	ID#	ID#	ID#	ID#
	CHECKED BY														
5. TANK VENTS	DATE AND RATING	ID#	ID#	ID#	ID#	ID#	ID#	ID#	ID#	ID#	ID#	ID#	ID#	ID#	ID#
	CHECKED BY														
6. CATHODIC PROTECTION	DATE AND RATING														
	CHECKED BY														
7. LINE STRAINERS	DATE AND RATING	ID#	ID#	ID#	ID#	ID#	ID#	ID#	ID#	ID#	ID#	ID#	ID#	ID#	ID#
	CHECKED BY														
8. WATER DEFENSE SYSTEM	DATE AND RATING	ID#	ID#	ID#	ID#	ID#	ID#	ID#	ID#	ID#	ID#	ID#	ID#	ID#	ID#
	CHECKED BY														
REMARKS(g)															
RETAIN ON FILE FOR 24 MONTHS															

RATINGS: S = SATISFACTORY; C = COMMENT (COMMENT REQUIRED IN REMARKS SECTION; N/U = NOT USED; N/A = NOT APPLICABLE)

FUELING VEHICLE REQUIREMENTS

CONTENTS

03-06.A	General	1
03-06.B	Requirements	1

A. GENERAL

1. Fueling vehicles and equipment servicing Company aircraft must meet the requirements in this section.
2. Vendors with existing vehicles which do not meet requirements of this section are to submit a request for Alternate Procedures per FSPM 02-01 [Ref. FSPM 02-01].
3. The vendor shall notify the Company in writing prior to using new or modified equipment per FSPM 03-00 [Ref. FSPM 03-00].

B. REQUIREMENTS

1. Must be equipped with either a filter/separator or a full flow fuel monitor. Filter/Separators must meet the current API/IP 1581; or be qualified by similarity as defined in API/IP 1582. If qualified by similarity, a similarity data sheet must be maintained locally and a data plate reflecting such qualifications must be attached to the filter vessel.

CAUTION

Full flow monitors must not be used with fuels containing Fuel System Icing Inhibitors (FSII). The water removal performance of full flow monitors may be reduced by fuel containing FSII.

2. Full Flow Fuel Monitors must meet the API/IP 1583 Specifications and Qualification Procedures – Aviation Fuel Filter Monitors with Absorbent Type Elements. Vendors using Full Flow Fuel Monitors shall have replacements on site or readily available from a local distributor. Service life of the elements of a Full Flow Fuel Monitor is one year or 15 psi maximum differential pressure, whichever occurs first.
 - a) Full Flow Fuel Monitors when used in systems that have a static fuel pressure in excess of 180 psig, shall be equipped with a differential pressure device, which will prevent excessive inlet pressure from rupturing elements in the event of complete blockage.
 - b) Filter/Separators shall be equipped with an Automatic Water Defense System which will cause fueling to stop when activated by excessive water, and include a Float or Electronic Probe System that has provisions for an operational test.
 - c) Filter/Separators and Full Flow Fuel Monitors are to include air elimination provisions, operational differential pressure gauge, manual sump drain, downstream filter membrane sampling taps, overpressure/thermal relief device and data plate.
3. The cargo tank must be constructed of stainless steel, aluminum or internal light color epoxy coated carbon steel and have a low point manual drain.
4. Fueling vehicles that have a Bottom Loading System must have an operational pre-check valve and High Level Shut-off System.
5. The following items shall be installed on all mobile jet fueling equipment:
 - a) Hand-held deadman control
 - b) Delivery nozzles with 100 mesh or finer screens
 - c) Emergency Fuel Flow Shut-off System
 - d) Fire Extinguishers
 - 1) Hydrant trucks or hydrant carts require one 20 lb. Dry Chemical Fire Extinguisher.
 - 2) Tank trucks require two 20 lb. Dry Chemical Fire Extinguishers (on opposite sides).
 - 3) If the Fire Extinguisher is located in an enclosed compartment, its location shall be clearly marked.
 - e) Separate and independent Primary and Secondary Pressure Control Systems
 - 1) Primary pressure control is intended to protect the aircraft under conditions of constant flow and also from pressure surge caused during aircraft valve closure. Primary pressure control devices must limit fueling pressure at the fuel nozzle to 40 psig or less under conditions of constant flow.

- 2) Secondary pressure control is intended to protect the aircraft in the event of primary pressure control failure. Secondary pressure control devices must limit fueling pressure, at the fuel nozzle, to 50 psig or less under conditions of constant flow.
 - 3) Fuel pressure control systems may utilize the following: pressure-controlling hydrant pit valves, pressure-controlling hydrant pit couplers, In-line pressure control valves, Hose End Pressure Control Valves (HEPCV), pressure switches that will cause rapid shutoff of fuel flow in the event of high fueling pressure.
- f) Bonding cables
 - g) Fueling pressure gauge visible during aircraft fueling operations
 - h) Product meter with NBS calibration capabilities
 - i) Dome covers shall be provided with a mounted hinge and latches that will automatically cause the cover to close with forward motion of the vehicle, and watertight, fuel resistant seals and gaskets.

NOTE

Dome covers incorporated into an interlock system are acceptable.

- j) Fuel hose meeting API 1592, Grade 2, Type C latest edition

NOTE

Hydrant coupler and aircraft fueling nozzle swivel retention devices must be equipped with at least two levels of redundancy, such as collar lock rings and collar retention screws secured by safety wire.

- k) Manual shut-off valve ahead of each delivery hose
- l) Brake Safety Interlocks or equivalent system
- m) Correct placards/decals
 - 1) Product Identification on each side and rear of equipment.
 - 2) "No Smoking" posted in cab and on least two sides of equipment.
 - 3) "Flammable" posted on each side and rear of equipment.
 - 4) Filter/Tank drain lines shall be identified.
 - 5) Brake safety interlock placards shall identify normal and override control positions.
 - 6) "Emergency Fuel Shutoff" placard adjacent to each emergency shutoff control. Placards must also indicate method of operation (e.g., Push, Pull, Turn, etc.).
 - 7) Aircraft fueling pressure or nozzle pressure gauge shall be identified.
 - 8) Filter differential pressure gauges shall be identified.
 - 9) A placard indicating the (Month and Year) during which the last filter elements were changed shall be placed on the filter housing.
 - 10) For newly manufactured fueling vehicles the last filter change date, on the placard, should indicate the date the equipment was placed into service.
- n) Dust covers or other protective device that prevent debris from accumulating on the mating surfaces of hose nozzles and hydrant couplers.

END

FUELING VEHICLE INSPECTIONS

CONTENTS

03-07.A	General	1
03-07.B	Daily Checks	1
03-07.C	Daily Aircraft Fueling Equipment Checklist	2
03-07.D	Monthly Checks	5
03-07.E	Monthly Aircraft Fueling Equipment Checklist	6
03-07.F	Quarterly Checks	8
03-07.G	Semi-Annual Checks	8
03-07.H	Annual Checks	8
03-07.I	Quarterly/Semi-Annual/Annual Aircraft Fueling Equipment Checklist	9

TABLES

Table FSPM 03-07.a	Instructions for Completing AE-FSPM-0307 Daily Fueling Equipment Checklist	2
Table FSPM 03-07.b	AE-FSPM-0307 Daily Fueling Equipment Checklist	4
Table FSPM 03-07.c	Instructions for Completing AE-FSPM-0307.1 Monthly Fueling Equipment Checklist	6
Table FSPM 03-07.d	AE-FSPM-0307.1 Monthly Fueling Equipment Checklist	7
Table FSPM 03-07.e	Instructions for Completing AE-FSPM-0307.2	9
Table FSPM 03-07.f	AE-FSPM-0307.2 Quarterly/Semi-Annual/Annual Fueling Equipment Checklist	10

A. GENERAL

1. Daily, monthly, quarterly and annual checks/inspections must be performed on fuel vehicles and equipment servicing Company aircraft and at the frequencies specified.

NOTE

Records, paper or electronic, must be completed by the person performing the tasks, or by the person accepting responsibility for performance of the tasks as referenced in FSPM 03-00 Fuel Quality Control Standards [Ref. FSPM 03-00].

2. Additional tasks such as those contained in Alternate Procedures or more frequent checks may be necessary based on local conditions or requirements.
3. Record inspections and initial rating on the appropriate Company form. Other forms may be used per FSPM 03-00 if they meet or exceed the inspection and frequency requirements contained in this Section [Ref. FSPM 03-00].
4. Any fuel vehicle not in continuous daily use must have the applicable checks performed and recorded before the unit is placed into service. Records must indicate when vehicles or equipment are not in service.

B. DAILY CHECKS

The daily check shall be performed each day including weekends/holidays and recorded on the Daily Fueling Equipment Checklist (AE-FSPM-0307) ([p 4](#)).

1. **General Condition** – Check the general condition of fueling vehicle for safety defects, equipment damage, fuel leaks, and appearance. Report and correct any condition that needs immediate attention (e.g., faulty brakes, faulty tires, broken or defective glass, defective windshield wipers, defective exhaust system, inoperable safety features, missing light and lenses, etc.). If there are any visible fuel leaks, the vehicle is to be immediately removed from service until corrective action is taken to repair the leaks.
2. **Filter Sumps** – Perform white bucket test of filter sumps. Record findings of first sample taken according to FSPM 03-10 [Ref. FSPM 03-10].
3. **Filter Differential Pressure** – Observe and record differential pressure with fuel flowing through filter under steady flow conditions (Ref. AE-FSPM-0314). Remove vehicle from service if differential pressures exceed 15 psi for Filter Separators and Full Flow Monitors. If desired, plot on Fuel Filter Vessel Record (AE-FSPM-0314). Remove unit from service if a sudden drop in differential pressure from previous readings is observed.
4. **Deadman Controls** – Check the satisfactory operation of the Deadman Control System. If unsatisfactory, remove fueling vehicle from service until corrected. (Time to shutdown is approximately five percent of actual flow rate at the time of release.)

Fueling and Servicing Procedures Manual

5. **Brake (Safety) Interlocks** – Check the satisfactory operation of the Brake or Safety Interlock System. Be sure that all brake or safety sensors installed are functioning satisfactorily and vehicle does not creep. If inoperative, Wheel Chocking Procedures must be used until Interlock System is repaired and operating properly. A minimum of one pair chocks to prevent forward or aft movement of vehicle is required. Interlock systems shall be equipped with an override device e.g., push-button, spring loaded toggle switch, lever device, etc. Regardless of the type and location, it shall be secured in the normal position with a breakaway seal. Placards must identify normal and override positions. A light, indicating override activation, is recommended and should be prominently located in the vehicle cab.
6. **Nozzle Fueling Pressure** – Check and record nozzle delivery (primary) fueling pressure. Normal fueling pressure should not exceed 40 psi. If pressure exceeds 40 psi, but less than 50 psi, investigate and correct deficiency. Remove vehicle from service if pressure exceeds 50 psi.
7. **Hoses, Swivels and Nozzles** – Check condition of all fuel hoses, swivels and nozzles for wear, damage and leakage. Check hoses for abrasions, cuts, soft spots, carcass separation, worn covers, blisters, exposed reinforcement, cracks, twists and sharp bends that give the appearance of impending failure. Check tightness of all swivel attachment screws and hose couplings. Check condition of nose and poppet seals on nozzles for cuts, nicks and wear. Any item that is defective or is leaking must be replaced or repaired immediately. Dust covers or other protective devices must be used to prevent debris from accumulating on the mating surface of nozzles.
8. **Bonding Reels, Cables and Clamps** – Check condition of static bonding reels, cables, clamps and bayonets. Defective equipment should be repaired or replaced immediately.
9. **Lift Platforms** – Check the general condition and proper operation of lift platforms. If deficiencies are noted, remove fueling vehicle from service until corrected.
10. **Fire Extinguishers** – Verify that fire extinguishers are in proper place with unobstructed access for immediate use. If seal is broken or inspection tag is missing, remove truck from service or replace fire extinguisher prior to fueling aircraft.
11. **Surge Tanks** – Atmospheric surge tanks, thermal relief tanks, or waste fuel tanks are to be checked or drained to protect against fuel overflow and spillage.
12. **Air Tanks** – Bleed air tanks to remove all moisture.
13. **Tanker Troughs** – Check tanker troughs for water. If standing water is present, check trough drains for plugging and use extra care in inspecting compartment and filter drains to ensure that water has not entered Fuel System. Clean troughs and drains as required.
14. **Tanker Sumps** – Perform white bucket check of each tank compartment. Record findings of first sample taken according to AE-FSPM-0310.
15. **Tanker Bottom Loading** – Before bottom loading tankers, manually operate the pre-check test provisions to ensure the satisfactory operation of the High Level Shutdown System. The pre-check test is to be performed at the beginning of each bottom loading fuel transfer. If the pre-check test or High Level Shutdown System does not operate properly, do no bottom load refuelers until system is repaired or Alternate Procedures are followed.

C. DAILY AIRCRAFT FUELING EQUIPMENT CHECKLIST

1. Each fueling vehicle must have a separate Daily Fueling Equipment Checklist (AE-FSPM-0307) ([p 4](#)) completed daily including the signature of the person performing the checks. The checklist is completed as follows:

Table FSPM 0307.a: Instructions for Completing AE-FSPM-0307 Daily Fueling Equipment Checklist

ITEM	DESCRIPTION	RESPONSIBILITY
a)	Enter station using three letter city code.	See Note at A.1. (p 1)
b)	Enter equipment identification number.	See Note at A.1. (p 1)
c)	Enter month and year.	See Note at A.1. (p 1)

Fueling and Servicing Procedures Manual

Table FSPM 0307.a: Instructions for Completing AE-FSPM-0307 Daily Fueling Equipment Checklist

ITEM	DESCRIPTION	RESPONSIBILITY
d)	Enter daily rating of each item listed for each day of the month. The following rating designators are to be used: S = Satisfactory C = Comment N/U = Not Used N/A = Not Applicable	See Note at A.1. (p.1)
e)	Enter signature of person performing tasks or person accepting responsibility that tasks were performed.	See Note at A.1. (p.1)
f)	Enter applicable remarks.	See Note at A.1. (p.1)

2. Disposition – Retain on file for 24 months.

CONTINUED ON FOLLOWING PAGE

Fueling and Servicing Procedures Manual

Table FSPM 0307.b: AE-FSPM-0307 Daily Fueling Equipment Checklist

AE-FSPM-0307
03 Nov 09

Daily Fueling Equipment Checklist

Daily - Use applicable Rating 1. General Condition 2. Filter Sumps - Record Ratings 3. Filter Differential Pressure - psi 4. Deadman Control 5. Brake Safety Interlocks 6. Nozzle Fueling Pressure 7. Hose, Nozzles and Swivels 8. Static Reels, Cables and Clamps 9. Lift Platforms 10. Fire Extinguishers 11. Surge/Waste Tanks 12. Air Tanks 13. Tanker Troughs 14. Tank Sumps - Record Ratings 15. Tanker Bottom loading Per-Check	Station - (a)			Equip. ID# - (b)						Month (c)					Year (c)																				
	1	2	3	4	5	6	7	8	9	10	11	12	13	14	15	16	17	18	19	20	21	22	23	24	25	26	27	28	29	30	31				
(d)																																			
(e)																																			

Signature of person performing task or person accepting responsibility that tasks were performed.

Ratings: S = Satisfactory C = Comment (Comment required in Remarks Section): N/U = Not Used N/A = Not Applicable
Sump Sample Ratings: Solids - 1 = Clean 2 = Slight 3 = Particulate 4 = Dirty: Water - A = Bright B = Hazy C = Cloudy D = Wet

Remarks: (f)

Retain on file for 24 months

D. MONTHLY CHECKS

The monthly check shall be performed monthly and recorded on the Monthly Fueling Equipment Checklist (AE-FSPM-0307.1) (p 7).

1. **Filtration Test and Free Water Test** – Perform a Membrane Filtration Test [Ref. FSPM 03-11] and Free Water Test [Ref. FSPM 03-12] downstream of filter. Record findings on Fuel Quality Test Record (AE-FSPM 0305).
2. **Bonding Cable Continuity Test** – Check electrical continuity of Bonding System [Ref. FSPM 03-15].
3. **Nozzle Screens** - Remove nozzles and examine screens for particles. Verify that screens are 100 mesh. Damaged screens are to be replaced. Investigate sources of contamination which could be inner hose lining, pipe rust, sand, low point sediment, equipment failure, seals, gaskets, etc. Screens are to be cleaned, or replaced if damaged.
4. **Fuel Hoses** – Lay hoses out full length and perform the monthly check while system is at full operating pressure. In addition, check couplings at both ends for slippage and signs of leakage. Immediate corrective actions are required if hoses or couplings show any defects.
5. **Signs and Placards** – Verify that fueling vehicle is clearly marked with applicable FLAMMABLE and product identification signs e.g., JET A. Other information and instruction markings may be required.
6. **Meter Seals** – Verify that meter calibrators/adjusters are sealed. Meters with missing seals may only be used with airline permission and must be calibrated.
7. **Fire Extinguishers** – Check fire extinguisher inspection tag dates, seals and verify that extinguishers are properly charged.
8. **Emergency Shutdown System** – Check the satisfactory operation of the Flow Emergency Shutdown System. If unsatisfactory, remove fueling vehicle from service until corrected.
9. **Deadman Control System** – Verify that the Deadman Control System will completely stop fuel flow before overrun has exceeded 5% of actual flow rate at the time of release. Equipment with a defective deadman control system must be removed from service until corrected.
10. **Lift Platforms** – Thoroughly check the safe and dependable operation of lift platforms. Inspection includes lift mechanism, Emergency Let Down System, lift interlocks, hydraulic hoses, couplings, lighting, electrical wiring, handrails, steps, working surface and signing. Correct deficiencies before returning vehicle to service.
11. **Tanker Interiors** – Check tank compartment interiors from dome cover opening for water, surfactants and other contaminants. Clean and drain as required. Check epoxy-coated tanks for deterioration.
12. **Tanker Vents and Dome Covers** – Check tank cover latches, hinges, seals and gaskets. Verify that hinges are forward mounted and will close with forward motion of the vehicle. Check condition of tank vents for freedom of operation. Correct as required.
13. **Tanker Trough Drains** – Manually check trough drains for plugging. Use cable or wire to ensure that there are no obstructions. More frequent checks may be required during inclement weather conditions.
14. **Corrected Filter Differential Pressure** – Under steady flow conditions, check and record observed differential pressure, flow rate and corrected differential pressure across each working filter.

CONTINUED ON FOLLOWING PAGE

E. MONTHLY AIRCRAFT FUELING EQUIPMENT CHECKLIST

1. A separate Monthly Fueling Equipment Checklist (AE-FSPM-0307.1) ([p 7](#)) is to be completed for each vehicle or equipment as follows:

Table FSPM 0307.c: Instructions for Completing AE-FSPM-0307.1 Monthly Fueling Equipment Checklist

ITEM	DESCRIPTION	RESPONSIBILITY
a)	Enter station using three letter city code.	See Note at A.1. (p 1)
b)	Enter equipment identification number.	See Note at A.1. (p 1)
c)	Enter rating of each item listed. The following rating designators are to be used: S = Satisfactory C = Comment N/U = Not Used N/A = Not Applicable	See Note at A.1. (p 1)
d)	Enter date of completion.	See Note at A.1. (p 1)
e)	Enter signature of person performing tasks or person accepting responsibility that tasks were performed.	See Note at A.1. (p 1)
f)	Enter applicable remarks.	See Note at A.1. (p 1)

2. Disposition – Retain on file for 24 months.

CONTINUED ON FOLLOWING PAGE

F. QUARTERLY CHECKS

The quarterly check shall be performed quarterly and recorded on the Quarterly/Semi-Annual/Annual Fueling Equipment Checklist (AE-FSPM-0307.2) ([p 10](#)).

1. **Vehicle Inspection** – A thorough overall inspection shall be performed of fueling components for leaks and pending equipment failures.
2. **Pressure Controls** – All fueling trucks, hydrant carts, and direct fueling cabinets will be pressure and flow tested each quarter. Tests are to consist of monitoring and adjusting primary and secondary control pressures. These units can be a valve, pressure switch, hose end controller or any other device that will stop or regulate fuel flow. Secondary controllers must not allow nozzle pressure to exceed 50 psi at steady rate of flow. Record Primary (40 psi) and Secondary (50 psi) fuel pressure setting.

CAUTION

Never adjust pressure control equipment while fueling aircraft.

NOTE

Daily nozzle pressure reading should be compared with the Quarterly Pressure Controls setting routinely to ensure the proper adjustments are maintained between Quarterly Pressure Controls checks.

NOTE

Operator must have written test procedures specific to the vehicle pressure control system.

3. **Water Defense Systems** – Check the satisfactory operation of water defense mechanisms on filter/separators in accordance with the Quarterly requirements of FSPM 03-16 [Ref. FSPM 03-16]. Immediately repair any deficiencies.
4. **Internal Valve Check** – Test to insure the internal valve functions properly, i.e., remains closed except when bottom loading or dispensing fuel.

G. SEMI-ANNUAL CHECKS

The semi-annual check shall be performed twice each calendar year and recorded on the Quarterly/Semi-Annual/Annual Fueling Equipment Checklist (AE-FSPM-0307.2) ([p 10](#)).

1. **Hose Pressure Checks** – Refueling hose fitted with reusable couplings and being operated under system pressure, must undergo six-month pressure testing at 225 psi.

H. ANNUAL CHECKS

The annual check shall be performed each calendar year and recorded on the Quarterly/Semi-Annual/Annual Fueling Equipment Checklist (AE-FSPM-0307.2) ([p 10](#)).

1. **Filter Elements** – Replace filter elements per FSPM 03-19. Life of filter elements may be extended to a maximum of two years provided the operator has followed criteria outlined in FSPM 03-19. Regardless of filter element replacement frequency, all filter vessels must be opened annually to visually check condition of interior for cleanliness and integrity of elements [Ref. FSPM 03-19].
2. **Nozzle Pressure Gauges and Differential Pressure Gauges** – Check accuracy of pressure gauges monitoring fuel pressure to aircraft and filter vessels. Replace or calibrate if found defective. Verify proper operation of filter differential gauge(s) in accordance with gauge manufacturers' procedures. Repair or replace as required. Inspect, clean or replace gauge lines and valves and any associated filters as necessary.
3. **Fuel Meters** – Check meter calibrations. Adjust meters to meet governing calibration requirements. Meter adjusters are to be properly sealed upon completion of calibration.
4. **Water Defense Systems** – Check the satisfactory operation of water defense mechanisms on filter/separators in accordance with the Annual requirements of FSPM 03-16. Immediately repair any deficiencies [Ref. FSPM 03-16].

I. QUARTERLY/SEMI-ANNUAL/ANNUAL AIRCRAFT FUELING EQUIPMENT CHECKLIST

1. The Quarterly/Semi-Annual/Annual Fueling Equipment Checklist (AE-FSPM-0307.2) ([p 10](#)) is a combination checklist. Use the appropriate portion for the checklist being conducted.

Fueling and Servicing Procedures Manual

2. A separate form is to be completed for each vehicle or equipment as follows:

Table FSPM 0307.e: Instructions for Completing AE-FSPM-0307.2

ITEM	DESCRIPTION	RESPONSIBILITY
a)	Enter station using three letter city code.	See Note at A.1. (p.1)
b)	Enter equipment ID number.	See Note at A.1. (p.1)
c)	Enter year.	See Note at A.1. (p.1)
d)	Enter rating of each item listed. The following rating designators are to be used: S = Satisfactory C = Comment, required in remarks section N/U = Not Used N/A = Not Applicable	See Note at A.1. (p.1)
e)	Enter date of check.	See Note at A.1. (p.1)
f)	Enter remarks as required.	See Note at A.1. (p.1)

3. Disposition – Retain on file for 24 months.

CONTINUED ON FOLLOWING PAGE

Fueling and Servicing Procedures Manual

Table FSPM 0307.f: AE-FSPM-0307.2 Quarterly/Semi-Annual/Annual Fueling Equipment Checklist

Quarterly/Semi-Annual/Annual Fueling Equipment Checklist					
	Station: (a)		Equip. ID#: (b)		Year: (c)
	1ST Quarter	2ND Quarter	3RD Quarter	4TH Quarter	
QUARTERLY CHECKS	(d)				
1. Vehicle Inspection Rating Checked by and Date	(e)				
2. Pressure Controls Rating Primary Fuel Pressure Setting in psi Secondary Fuel Pressure Setting in psi Checked by and Date					
3. Water Defense System Test Rating Checked by and Date					
4. Internal Valve Check Rating Checked by and Date					
SEMI-ANNUAL CHECKS					
1. Hose Pressure Check Rating Test Pressure (psi) Checked by and Date					
ANNUAL CHECKS					
1. Filter Element Change Rating Checked by and Date					
2. Fueling and Differential Pressure Gauge Rating Checked by and Date					
3. Meter Calibration Rating Checked by and Date					
4. Water Defense System Inspection and Test Rating Checked by and Date					
Ratings: S = Satisfactory, C = Comment, (Comment required in remarks section) N/A = Not Applicable, N/U = Not Used Remarks:					
(f)					
Retain on file for 24 Months					

HYDRANT SYSTEM CHECKS

CONTENTS

03-08.A	General	1
03-08.B	Daily Checks	1
03-08.C	Monthly Checks	2
03-08.D	Quarterly Checks	2
03-08.E	Annual Checks	3
03-08.F	Daily Hydrant System Checklist	3
03-08.G	Monthly Hydrant System Checklist	3
03-08.H	Quarterly/Annual Hydrant System Checklist	4

TABLES

Table FSPM 03-08.a	Instructions for Completing AE-FSPM-0308 Daily Hydrant System Checklist	3
Table FSPM 03-08.b	Instructions for Completing AE-FSPM-0308.1 Monthly Hydrant System Checklist	3
Table FSPM 03-08.c	Instructions for Completing AE-FSPM-0308.2 Quarterly/Annual Hydrant System Checklist	4
Table FSPM 03-08.d	AE-FSPM-0308 Daily Hydrant System Checklist	5
Table FSPM 03-08.e	AE-FSPM-0308.1 Monthly Hydrant System Checklist	6
Table FSPM 03-08.f	AE-FSPM-0308.2 Quarterly/Annual Hydrant System Checklist	7

A. GENERAL

1. The following checks must be performed on all hydrant pits used to service Company aircraft and at the frequencies specified. Additional tasks such as those contained in Alternate Procedures or more frequent checks may be required based on local conditions or requirements.

NOTE

Records, paper or electronic, must be completed by the person performing the tasks, or by the person accepting responsibility for performance of the tasks as referenced in FSPM 03-00 Fuel Quality Control Standards [Ref. FSPM 03-00].

2. Ramp hydrant pits are susceptible to the accumulation of water/fuel and debris. It is necessary that these pits be inspected daily with all findings recorded.
3. Record checks on the appropriate Hydrant System Checks Form. Other forms may be used if they meet or exceed the task and frequency requirements.
4. The Company is to be notified by the vendor before an additional, replacement or modified fueling vehicle is placed into service fueling Company aircraft. At the Company's option, fueling vehicle may be inspected and approved for use prior to fueling Company aircraft.
5. All personnel engaged in ramp operations must be continuously observant of abnormal conditions that may exist in and around hydrant pits. Any fuel leaks, fire/safety hazards or adverse conditions must be reported immediately.
6. Hydrant Pit Systems or segments of Hydrant Pit Systems not in continuous use for a period of six months or more must have all frequency checks performed and recorded before the system is placed into service. Based on fuel test results, flushing may be required prior to use. Records must indicate when systems are out-of-service.
7. Out-of-service pits are to be locked, secured or otherwise unusable.

B. DAILY CHECKS

A daily hydrant pit inspection shall be performed, including weekends and holidays, and recorded on the Daily Hydrant System Checklist (AE-FSPM-0308) ([p 5](#)). The check requires the following:

1. Hydrant Pit

- a) Visually check hydrant pits and all components for deficiencies. Correct deficiencies in a timely manner.
- b) Pits should be clean and free of standing liquid. Remove any paper or other foreign debris. Hydrant pits are to be kept clean and dry. Pits are to be removed from service if liquid level covers lowest flange or is within 12 inches of top of pit valve. Pump out any accumulation of water.

NOTE

On occasions of severe rain/melting snow, do this more frequently. In no case should an aircraft be fueled when the liquid level is above the top of the hydrant valve.

Fueling and Servicing Procedures Manual

2. Emergency Fuel Shutoff (EFS) Stations

- a) Verify that all emergency fuel shutoff stations on the ramp have:
 - 1) Clear access.
 - 2) A sign or placard identifying EFS location.
- b) Any deficiencies are to be reported and corrected immediately.

C. MONTHLY CHECKS

A monthly hydrant pit inspection shall be performed and recorded on the Monthly Hydrant System Checklist (AE-FSPM-0308.1) ([p 6](#)). The check requires the following:

1. Isolation Valve Pits and Control Vaults

- a) Check Isolation valve pits for:
 - 1) Emergency access
 - 2) Fuel leaks
 - 3) Standing liquid and debris
 - 4) General condition of all components
- b) Correct deficiencies in a timely manner.

2. Hydrant Valve Assembly

- a) Check the general condition of the hydrant pit valve and sense line connectors.
- b) Verify the satisfactory operation of the hydrant pit valve.
- c) Check for leaks, excessive coupler mating flange wear and loose or missing fasteners.
- d) Promptly correct any deficiencies.

3. Low Point Drains

- a) Open all low point drains until all water/sediment is removed.
- b) Flush a minimum of two gallons at each low point until clear fuel is obtained to ensure positive removal of all contaminants.
- c) Replace missing tags or markings to pit lids or low point drain valves as required to ensure proper identification.

4. Emergency Fuel Shutoff

- a) Verify the satisfactory operation of the Emergency Shutdown System by actuating one or more of the control devices for each zone.
- b) Coordinate the shutoff test with all persons, fueling agents, fuel suppliers and any other group having an interest in the operation of the facility.
- c) Each control device must be tested at least once per year.
- d) Immediately repair any discrepancies.

NOTE

If for any reason the Emergency Shutdown System cannot be repaired immediately, the system operator must put into effect an approved alternate plan for continuing system use until the discrepancies can be corrected.

D. QUARTERLY CHECKS

A Quarterly hydrant pit inspection shall be performed and recorded on the Quarterly Hydrant System Checklist (AE-FSPM-0308.2) ([p 7](#)). The check requires the following:

1. High Point Vents

- a) Bleed all high point vents to ensure the removal of all entrapped air.
 - b) Continue to bleed air until clear fuel is present.
 - c) It is necessary to bleed high point vents more frequently if pipeline was drained or modified, allowing air entry into system.
-

d) Replace missing tags or markings to pit lids or high point vent valves as required to ensure proper identification.

2. Surge Absorbers

- a) Where installed, check the general condition and operating pressure setting of each unit.
- b) Recharge as required.

NOTE

In critical areas; e.g., baggage rooms, basements, etc., this task may be required more frequently.

E. ANNUAL CHECKS

Annual hydrant pit inspection shall be performed and recorded on the Quarterly/Annual Hydrant System Checklist (AE-FSPM-0308.2) (p.7). The check requires the following:

1. **Cathodic Protection** – Where installed, confirm satisfactory operation of cathodic protection systems. This requirement is generally contracted to businesses specializing in this type of service. State or local regulations may require greater frequency of inspection.

F. DAILY HYDRANT SYSTEM CHECKLIST

1. The Daily Hydrant System Checklist (AE-FSPM-0308) (p.5) is to be completed as follows:

Table FSPM 0308.a: Instructions for Completing AE-FSPM-0308 Daily Hydrant System Checklist

ITEM	DESCRIPTION	RESPONSIBILITY
a)	Enter station using three letter city code.	See Note at A.1. (p.1)
b)	Enter the facility name.	See Note at A.1. (p.1)
c)	Enter the date.	See Note at A.1. (p.1)
d)	Enter the ID # of the pit being checked.	See Note at A.1. (p.1)
e)	Enter rating of each item listed. The following rating designators are to be used: S = Satisfactory C = Comment, required in remarks section. N/U = Not Used N/A = Not Applicable	See Note at A.1. (p.1)
f)	Enter signature of person performing check.	See Note at A.1. (p.1)

2. Disposition – Retain on file for 24 months.

G. MONTHLY HYDRANT SYSTEM CHECKLIST

1. The Monthly Hydrant System Checklist (AE-FSPM-0308.1) (p.6) is to be completed as follows:

Table FSPM 0308.b: Instructions for Completing AE-FSPM-0308.1 Monthly Hydrant System Checklist

ITEM	DESCRIPTION	RESPONSIBILITY
a)	Enter station using three letter city code.	See Note at A.1. (p.1)
b)	Enter the facility name.	See Note at A.1. (p.1)
c)	Enter the date.	See Note at A.1. (p.1)

Fueling and Servicing Procedures Manual

Table FSPM 0308.b: Instructions for Completing AE-FSPM-0308.1 Monthly Hydrant System Checklist

ITEM	DESCRIPTION	RESPONSIBILITY
d)	Enter ID # of the Pit Vault or Low point Assembly to be checked.	See Note at A.1. (p 1)
e)	Enter rating of each item listed. The following rating designators are to be used: S = Satisfactory C = Comment, required in remarks section. N/U = Not Used N/A = Not Applicable	See Note at A.1. (p 1)
f)	Enter signature of person performing check.	See Note at A.1. (p 1)

2. Disposition – Retain on file for 24 months.

H. QUARTERLY/ANNUAL HYDRANT SYSTEM CHECKLIST

1. The Quarterly/Annual Hydrant System Checklist (AE-FSPM-0308.2) (p 7) is to be completed as follows:

Table FSPM 0308.c: Instructions for Completing AE-FSPM-0308.2 Quarterly/Annual Hydrant System Checklist

ITEM	DESCRIPTION	RESPONSIBILITY
a)	Enter station using three letter city code.	See Note at A.1. (p 1)
b)	Enter the quarter and the year that checks are being completed in.	See Note at A.1. (p 1)
c)	Enter the facility name.	
d)	Enter ID # of item being checked.	See Note at A.1. (p 1)
e)	Enter rating of each item listed. The following rating designators are to be used: S = Satisfactory C = Comment, required in remarks section. N/U = Not Used N/A = Not Applicable	See Note at A.1. (p 1)
f)	Enter signature of person performing check.	See Note at A.1. (p 1)
g)	Enter remarks as required.	See Note at A.1. (p 1)

2. Disposition – Retain on file for 24 months.

CONTINUED ON FOLLOWING PAGE

CLEAR AND BRIGHT TEST

CONTENTS

03-09.A	General	1
03-09.B	Description of Test	1
03-09.C	Equipment	1
03-09.D	Procedures	1
03-09.E	Rating of Sample	2

TABLES

Table FSPM 03-09.a	Solid Contaminant and Moisture Content Indicators	2
--------------------	---	---

A. GENERAL

1. The purpose of the Clear and Bright Test is to visually detect the presence of undissolved water, sediment and suspended matter in turbine fuel. This test is not required by the Company, however it may be requested as an acceptable Alternate Procedure to the White Bucket Test per FSPM 02-01 [Ref. FSPM 02-01].
2. Jet A normally ranges in appearance from no color to a definite straw color. A straw colored product or a product having no color can be both Clear and Bright which means that fuel is visually free from undissolved water, sediment and suspended matter. A product suitably free from these contaminants produces a bright sparkling appearance.
3. For a complete description of the Clear and Bright Test, including pass-fail criteria, see ASTM D 4176. Copies may be obtained from:

American Society of Testing and Materials
1916 Race Street
Philadelphia, Pennsylvania 19103

B. DESCRIPTION OF TEST

1. A fuel sample is obtained in a clear glass cylindrical container and observed to ensure it is Clear-and-Bright.

C. EQUIPMENT

1. Equipment consists of a clean, clear glass container of at least one quart capacity.

D. PROCEDURES

1. Ensure that the container and the sampling tap are clean.
2. Draw a minimum of one quart of fuel into a clear glass cylindrical container.
3. Swirl sample to create a vortex and inspect. Visually detectable particulate matter will appear at the lower tip of the vortex. Undissolved (i.e., free) water will appear as a separate layer below the product when the swirling action stops. A hazed sample usually indicates either suspended free water or very fine particulate matter.
4. Rate the product per paragraph "Rating of Sample", below. If rating shows any particulate matter, is wet, hazy, cloudy, dirty or has any surfactants, accomplish the following:
 - a) Storage Facilities
 - 1) **Storage Tank Sumps** – Drain at maximum velocity beyond capacity of sample piping to ensure complete displacement of volume in piping. After piping volume is displaced, drain until contaminants are removed, to a maximum of five gallons. Additional sump testing is required before fuel is received into storage, after receipt, during and after heavy rainfall.
 - 2) **Filter Sumps** – Drain at maximum velocity beyond capacity of sample piping to ensure complete displacement of volume in piping. After piping volume is displaced, drain under pressure until contaminants are removed, to a maximum of five gallons.
 - b) Into-Plane Vehicles and Equipment
 - 1) **Tanker Sumps** – Drain a reasonable amount until contaminants are removed. Additional sump testing is required during and after heavy rainfall.
 - 2) **Filter Sumps** – Drain under pressure until contaminants are removed.

- c) If contaminants can not be removed, the condition must be investigated and corrected. The Company must be notified per FSPM 03-00 if fueling system becomes inoperable due to contamination and disrupts or may disrupt the Company's operation [Ref. FSPM 03-00].

E. RATING OF SAMPLE

1. Solid Contaminant and Moisture Content Indicators (Example: "2C" means there is slight particulate matter with cloudy condition in the sample.)

Table FSPM 0309.a: Solid Contaminant and Moisture Content Indicators

SOLIDS CONTAMINANT	MOISTURE CONTENT
1. Clean	A. Bright
2. Slight Particulate Matter	B. Hazy
3. Particulate Matter	C. Cloudy
4. Dirty	D. Wet (Free Water)
	E. Surfactants

2. Rating definitions of Solids Contaminant Indicators
- Clean** – Refers to lack of particles, silt or sediment, flakes or dye, rust or solids.
 - Slight Particulate Matter** – Contains several fine to moderate sized particles.
 - Particulate Matter** – A sample in which many small particles may be seen floating or settled on the bottom.
 - Dirty** – Discoloration or many particles dispersed in the fuel or settled on the bottom.
3. Rating definitions of Moisture Content Indicators:
- Bright** – Brightness is a quality independent of the color of the sample and refers to the lack of suspended or free water in the sample. Bright fuel tends to sparkle.
 - Hazy** – A condition resulting from fine droplets of moisture dispersed throughout the sample producing a dull hazy appearance. This can be a temporary condition brought about by a drop in temperature. During the first minute, the fuel can appear hazy due to air bubbles. To determine the difference between a haze caused by entrained water or air bubbles, perform a water detection test per FSPM 03-12 [Ref. FSPM 03-12].
 - Cloudy** – The result of extremely fine droplets of water or air dispersed throughout the sample giving it a milky appearance. To determine if cloudy condition is caused by water, perform a water detection test per FSPM 03-12 [Ref. FSPM 03-12].
 - Wet** – Any form of free water in the form of droplets or bulk water on the bottom of the bucket or clinging to the sides.
 - Surfactants** – Slime in the bottom of the bucket or at the fuel/water interface appears as a dark brown/black layer; or scum or lacy material floating in or on the sample.

END

WHITE BUCKET TEST

CONTENTS

03-10.A	General	1
03-10.B	Description of Test	1
03-10.C	Equipment	1
03-10.D	Procedures	1
03-10.E	Rating of White Bucket Sample	2
03-10.F	Action Required if Red Dye is Detected	2
03-10.G	Recoverable Product Intended for Aviation Use	3

TABLES

Table FSPM 03-10.a	Solids Contaminant and Moisture Content Indicators	2
--------------------	--	---

A. GENERAL

1. The purpose of this test is to visually determine the possible presence of surfactants, water and/or solids in turbine fuel.
2. White Bucket Test is accomplished daily per FSPM 03-05 and 03-07 and during fuel receipt per FSPM 03-02 and 03-03 [Ref. FSPM 03-05, FSPM 03-07, FSPM 03-02, FSPM 03-03].

B. DESCRIPTION OF TEST

1. A fuel sample is obtained in a clean white bucket from sump drains of filter vessels and tanks, and observed for indications of surfactants, presence of water, solids and off-colored fuel.

C. EQUIPMENT

1. Preferred equipment consists of a nine quart white porcelain bucket and a shiny object with definition. The white bucket can be obtained from Gammon Technical Products, #GTP-1746C.

D. PROCEDURES

1. Fill the white bucket with two gallons of fuel.
 - a) To ensure accuracy, fuel should be taken from a pressurized system if possible.
 - b) Ensure fuel sampling tap and white bucket are clean and free of loose contaminants.
2. Place on a level surface and allow sample to settle for one minute to remove air bubbles.
3. Place the white bucket on a level surface and inspect the bottom for water droplets, solid contaminants, hazy/cloudy condition and/or brown slime.
4. Drop a shiny object with definition into the bucket.
5. Check for red dye per paragraph "Action Required if Red Dye is Detected" ([p 2](#)).
6. Rate the product per paragraph "Rating of White Bucket Sample" ([p 2](#)). If rating shows any particulate matter, is wet, hazy, cloudy, dirty or has any surfactants, accomplish the following:
 - a) Storage Facilities
 - 1) **Storage Tank Sumps** – Drain at maximum velocity beyond capacity of sample piping to ensure complete displacement of volume in piping. After piping volume is displaced, drain until contaminants are removed, to a maximum of five gallons. Additional sump testing is required before fuel is received into storage, after receipt, during and after heavy rainfall.
 - 2) **Filter Sumps** – Drain at maximum velocity beyond capacity of sample piping to ensure complete displacement of volume in piping. After piping volume is displaced, drain under pressure until contaminants are removed, to a maximum of five gallons.
 - b) Into-Plane Vehicles and Equipment
 - 1) **Tanker Sumps** – Drain a reasonable amount until contaminants are removed. Additional sump testing is required during and after heavy rainfall.
 - 2) **Filter Sumps** – Drain under pressure until contaminants are removed.
- c) Record rating of first sample taken on applicable forms. Continue to sample until clean, dry fuel is obtained.

- d) If contaminants can not be removed, the fuel is to be quarantined and the condition must be investigated and corrected. The Company must be notified per FSPM 03-01 if contaminants are found in fuel during receipt or if fueling system becomes inoperable due to contamination and disrupts or may disrupt the Company's operation. Fueling or fuel receipt is not to be resumed from that source until the reason for the problem is found and corrected [Ref. FSPM 03-01].

E. RATING OF WHITE BUCKET SAMPLE

1. Solids Contaminant and Moisture Content Indicators (Example: "2C" means there is slight particulate matter with cloudy condition in the sample):

Table FSPM 0310.a: Solids Contaminant and Moisture Content Indicators

SOLIDS CONTAMINANT	MOISTURE CONTENT
1. Clean	A. Bright
2. Slight Particulate Matter	B. Hazy
3. Particulate Matter	C. Cloudy
4. Dirty	D. Wet (Free Water)
	E. Surfactants

2. Rating definitions of Solids Contaminant Indicators:
- Clean** – Refers to lack of particles, silt or sediment, flakes or dye, rust or solids.
 - Slight Particulate Matter** – Contains several fine to moderate sized particles.
 - Particulate Matter** – A sample in which many small particles may be seen floating or settled on the bottom.
 - Dirty** – Discoloration or many particles dispersed in the fuel or settled on the bottom.
3. Rating definitions of Moisture Content Indicators:
- Bright** – Brightness is a quality independent of the color of the sample and refers to the lack of suspended or free water in the sample. Bright fuel tends to sparkle.
 - Hazy** – A condition resulting from fine droplets of moisture dispersed throughout the sample producing a dull hazy appearance. This can be a temporary condition brought about by a drop in temperature. During the first minute, the fuel can appear hazy due to air bubbles. To determine the difference between a haze caused by entrained water or air bubbles, perform a water detection test per FSPM 03-12 [Ref. FSPM 03-12].
 - Cloudy** – The result of extremely fine droplets of water or air dispersed throughout the sample giving it a milky appearance. To determine if the cloudy condition is caused by water, perform a water detection test per FSPM 03-12 [Ref. FSPM 03-12].
 - Wet** – Any form of free water in the form of droplets or bulk water on the bottom of the bucket or clinging to the sides.
 - Surfactants** – Slime in the bottom of the bucket or at the fuel/water interface appears as a dark brown/black layer, or scum or lacy material floating in or on the sample.

F. ACTION REQUIRED IF RED DYE IS DETECTED

1. The white bucket test is to be used to inspect for red dye contamination. The inspector (with normal vision or wearing corrective non-tinted lenses) performs a visual examination of the fuel for color under normal daylight conditions or in any well-lighted room such as an office with fluorescent lighting. If the inspector is not sure of the fuel color, a consensus of the color should be obtained from several individuals.
- Jet fuel with no visible red tint should be judged acceptable for use in aircraft.
 - A red tint resulting from refinery processing will usually disappear when exposed to light. Jet fuel is acceptable for use if the red tint disappears in less than 30 minutes after being exposed to light.
 - If red tint does not disappear, the Company must be notified and fuel must be quarantined and recertified to ASTM D1655 specifications.

G. RECOVERABLE PRODUCT INTENDED FOR AVIATION USE

1. Recoverable product must be handled carefully to prevent contamination. Containers or equipment used for handling recovered product must be clean and dedicated to that purpose (e.g., equipment used for cleaning hydrant pits shall not be used for handling reclaimed product). Every effort should be made to remove visible solids and water (waste fuel) prior to moving fuel into a reclaim tank or returning to storage from a reclaim tank.

Fuel eligible for reclaim shall be limited to fuel from the following sources:

- a) Tank sumps
- b) Filter sumps
- c) Low point drains
- d) High point vents
- e) Equipment maintenance:
 - 1) Filter changeout
 - 2) Draining tanks for inspection/cleaning/repair
- f) Samples from:
 - 1) Fuel truck receipts
 - 2) Membrane filtration tests
 - 3) Gravity/Density checks

CAUTION

Fuel from any source other than those listed above shall not be reclaimed.

END

MEMBRANE FILTRATION TEST

CONTENTS

03-11.A	General	1
03-11.B	Description of Test	1
03-11.C	Equipment	1
03-11.D	Procedures	1

A. GENERAL

1. The purpose of this test is to provide a field method for detection of particulate matter in jet fuel. It is particularly useful in monitoring the cleanliness of fuel received and in evaluating the performance of filter vessels. Because the method produces results which are not quantitative, it is not to be used as the basis for rejection of product. It does, however, provide an alert signal which indicates the need for further investigation using other methods.
2. Membrane Filtration Test is accomplished monthly per FSPM 03-05 and 03-07 and during fuel receipt by pipeline or marine vessel per FSPM 03-02 [Ref. FSPM 03-05, FSPM 03-07, FSPM 03-02].

B. DESCRIPTION OF TEST

1. A fuel sample is obtained from a test sample port to monitor the cleanliness of fuel received and evaluate the performance of filter vessels.

C. EQUIPMENT

1. Equipment consists of a test kit containing membrane and support pad, test pad canister, canister housing and appropriate port connections and fluid drain lines. This test kit may be obtained from Gammon Technical Products, #GTP - 3318-100 or equivalent.

D. PROCEDURES

1. Install kit and flush a minimum of one gallon through line per kit instructions.
2. After flush is completed, take the monitor membrane sample using one gallon from a flowing stream. Static sampling must not be performed.
3. After the required one gallon has passed through the monitor membrane, disconnect the sample canister.
4. Close all test valves and replace end caps to the monitor membrane housing.

NOTE

It is not recommended to perform monitor membrane tests while refueling aircraft.

5. Perform visual assessment of membrane as follows:

NOTE

For color assessment use the color evaluation scales adopted by ASTM as outlined in Method D2276 for particulate and color assessment.

- a) Of the several methods available for assessing Millipore monitors, the visual method most readily lends itself to field evaluation quality.
- b) In making a visual assessment, the intensity of the background color of the membrane, which is caused by extremely fine particles and/or, the dyeing effect of liquid contaminants in the fuel, should be evaluated separately from the large visible particles. To this end, a three scale (A, B & G) Color Assessment Guide, having a scale from A through I, are to be used (Jet Fuel Color and Particulate Assessment Guide).
- c) Match the color intensity of the membrane to the closed matching color scale and graduation number. Various fuels and contaminants will give different background colors. Most fall in the pinkish tan, yellowish tan or gray orange, represented by Scales A, B and G respectively. Other background colors can be matched by comparing their relative intensities to the example. The "Whiteness" of the outside ring on the membrane may be a helpful guide. Note the color of the membrane by scale and graduation number. Example A3 matches graduation 3 on the A scale.
- d) Repeat the procedure using the Particle Assessment Guide. In using this guide, ignore the background color and match only the visible particles, comparing size and number. Note the values A through I.
- e) The complete assessed value should be reported by showing the color assessment value first (scale letter and graduation number), followed by the particle assessment value letter. Example: A3-A, G7-H., etc.

CAUTION

The operator should be aware of the fact that a wet membrane will appear two to three standard rating numbers darker than a dry membrane. This must be taken into consideration if there is a need for immediate evaluation. Official ratings are to be made after the membrane is completely dry using the official ASTM Rating Guide described in D-3830.

In some cases, it may be desirable to determine solids content of jet fuel using a quantitative method. This is commonly known as the Gravimetric Technique - ASTM Method D-2276. Results are expressed in terms of milligrams of solids per gallon or per liter as determined by a qualified laboratory. The primary use is to differentiate between color bodies (which may appear using the Color Method D-3830) and actual dirt. A copy of the method may be obtained from:

*American Society for Testing and Materials
1916 Race Street
Philadelphia, PA 19103*

6. Whether wet or dry, a membrane with visible particles is cause for concern. If test results are not acceptable, the fuel is to be quarantined and the condition must be investigated and corrected. The Company must be notified per FSPM 03-00 if contaminants are found in fuel during receipt or if fueling system becomes inoperable due to contamination and disrupts or may disrupt the Company's operation [Ref. FSPM 03-00].

END

FREE WATER TEST

CONTENTS

03-12.A	General	1
03-12.B	Visual Detection	1
03-12.C	Water Detection Kits	2

A. GENERAL

1. Dry fuel is a prime contributor to flight safety. Water in fuel, in addition to not burning in an engine, will freeze at the low temperatures encountered in high altitude flights and may facilitate the corrosion of some metals and the growth of microorganisms.
2. There are numerous ways that water enters fuel systems; the most common are:
 - a) Leakage at manholes and tank plumbing
 - b) Water-laden transport deliveries
 - c) Condensation of atmospheric moisture in partially filled storage tanks
3. The Company is concerned with water in fuel that occurs in one of two forms:
 - a) Dissolved Water (water in solution)

Dissolved water is best described as a condition similar to humidity in the air. The amount of dissolved water in fuel varies with the fuel temperature. The higher the fuel temperature, the higher the concentration of dissolved water. When the temperature of the fuel is reduced due to change in ambient temperature or in flight, especially at high altitudes, dissolved water will condense from the fuel and become free water.
 - b) Free water (water as separate liquid)

Free water exists as a separate liquid in fuel, is heavier than fuel and will settle to the bottom of tanks and accumulate in low points in fuel systems and can cause various problems. The most serious being engine flameout if a slug of water reaches the engine, and the formation of ice crystals, which may block fuel filters and fuel control units. Therefore, free water is not permitted to accumulate or remain in fuel systems and free water testing must be performed as prescribed throughout this manual.
4. Free Water Test is accomplished monthly per FSPM 03-05 and 03-07, and during fuel receipt by pipeline or marine vessel per FSPM 03-02 [Ref. FSPM 03-05, FSPM 03-07, FSPM 03-02].
5. If free water test results are not acceptable, the fuel is to be quarantined and the condition must be investigated and corrected. The Company must be notified per FSPM 03-01 if free water is found in fuel during receipt or if fueling system becomes inoperable due to free water and disrupts or may disrupt the Company's operation. Fueling or fuel receipt is not to be resumed from that source until the reason for the problem is found and corrected [Ref. FSPM 03-01].

B. VISUAL DETECTION

1. Over the years, various tests have been developed. However, experience has shown that the human senses can not be substituted.
2. The Company requires a visual inspection as the primary method for fuel being received and for the daily detection of free water above 30 ppm.
3. Large quantities of water in fuel can be seen while performing a White Bucket Test [Ref. FSPM 03-10]:
 - a) Free water will quickly separate from fuel and settle on the bottom of the sample container.
 - b) Dissolved water will separate from fuel over time and become free water, but until such time, it will appear cloudy.
 - c) Jet fuel also varies in color from dark straw to water white, so it is possible to mistake an all water sample for fuel. If there is any question about whether a fuel sample consists of only water or contains water, add a known quantity of water to fuel.
 - 1) If the sample contains fuel, the water will quickly separate and settle to the bottom of the sample.
 - 2) If the sample is all water, the added water will not separate.
 - d) For additional clarity, a drop of liquid food coloring may be added to the sample. The food coloring will separate from the fuel and settle to the bottom of the sample and color the water when mixed.
4. If there is any question about the presence of water, a more accurate detection method shall be utilized.

C. WATER DETECTION KITS

1. Envoy observes the specifications in ATA Spec 103 for operations within the United States and Mexico. In order to accomplish this, the Company requires monthly testing using one of the methods outlined below. This testing shall be the primary method for the detection of free water in fuel being dispensed into Company aircraft. The maximum allowable limit for water is 15 ppm.

NOTE

For fuel service providers located in Canada, the maximum allowable limit for water is 30 ppm.

2. All free water test kits mentioned herein are known to be commercially available. Manufacturer's instructions are to be followed when using these kits. Kits that have exceeded their expiration dates are not to be used.
 - a) Velcon Hydrokit. The test consists of adding fuel to a vial containing a pre-measured amount of water-sensitive powder. If water is present, the powder turns pink. Two kits are available: one with chemical powder sensitive to water concentrations greater than 15 ppm; the other kit with sensitivity greater than 30 ppm.
 - b) Metrocator Kit. The test, which may be used in detecting free water in concentrations from 5 ppm to greater than 60 ppm, consists of adding a pre-measured amount of water-sensitive powder to a sample of fuel in a special bottle. A disc of filter paper is placed in the screw cap of the bottle. After shaking the contents, blue spots appear on the test wafer or disk, and when compared to a standard, indicate the amount of water that is present in the fuel.
 - c) Aqua-Glo Kit. The test is capable of detecting free water concentrations as low as 1 ppm. The test consists of passing a measured amount of fuel through a chemically coated paper disc. The disc is then compared to a known color standard. The chemical will glow in ultraviolet light proportional to the amount of water in the fuel.
 - d) Shell Water Detection Kit. The test consists of drawing fuel through a capsule containing a water-sensitive chemical. If free water is present, the chemical changes color. The color changes become progressively more noticeable with increasing water concentrations until, at approximately 30 ppm, with a 5 ml sample, a strong, obvious green color is obtained.

END

API GRAVITY TEST

CONTENTS

03-13.A	General	1
03-13.B	References	1
03-13.C	Description of Test	1
03-13.D	Equipment	1
03-13.E	API Gravity Test Procedure	2

TABLES

Table FSPM 03-13.a	API Gravity Temperature Correction Table	4
--------------------	--	---

A. GENERAL

1. The purpose of this procedure is to provide the method for measuring the API gravity of fuel with a hydrometer. A significant change in API gravity may indicate contamination by another product.
2. Another use of hydrometers at airports is to determine fuel weight at the fueling temperature. In this case, temperature correction is not made and measurement is reported as "observed" or "uncorrected".
3. Hydrometers may be calibrated in one of the following units of gravity measurement: API Gravity, Relative Density (Specific Gravity) or Density. To avoid repeating these measurement terms, the term "density" will be used in this Section as a general term when referring to units of API gravity measurement.

B. REFERENCES

1. ANSI/ASTM D 1298 Standard Test Method for Density (API Standard 2540) Relative Density (Specific Gravity) or API Gravity of Crude Petroleum and Liquid Products by Hydrometer Method
2. ANSI/ASTM D 287, API Standard 2544 Standard Test Method for API Gravity of Crude Petroleum Products (Hydrometer Method)
3. ASTM E 100 Standard Specification for ASTM Hydrometers
4. ASTM E 1 Standard Specification for ASTM Hydrometers
5. ANSI/ASTM 250 Conversion Tables

C. DESCRIPTION OF TEST

1. Once a batch of fuel is produced, its corrected gravity remains relatively constant and must be from 37 through 51 units of API Gravity, using a hydrometer reading corrected to a standard temperature of 60°F. A significant change in gravity from that previously determined could indicate contamination with another product and should be investigated immediately. If there is a sudden change in API gravity of one unit or more from the same source or supplier, immediate investigation is required. Very slight differences in test results may occur due to differences in test operators or sample location, but these are usually minimal, such as less than 0.3 API.
2. The procedure is accomplished by taking a scale reading at the intersection of the fuel surface on a freely floating hydrometer and the temperature of the fuel recorded at the time of the test. The observed readings are then used to correct the gravity to the standard temperature for the test. The results are used to detect possible contamination of fuel by comparing previous gravity measurements of the same batch of fuel.

D. EQUIPMENT

1. ASTM-approved thermohydrometers graduated in units API Gravity and degrees F as specified in ASTM E 100. Thermohydrometers recommended for Jet A/A-1 are designated ASTM 54HL and 55HL. Thermohydrometers recommended for Jet B are designated 55HL and 56HL. The thermohydrometers recommended for aviation gasoline are designated ASTM 57HL and 58HL.
2. ASTM-approved plain form hydrometers graduated in units of density, relative density (specific gravity) or API gravity. These must conform to requirements outlined in ASTM E 100. Plain form hydrometers do not contain a built-in thermometer.

NOTE

Hydrometers are delicate instruments, which are easily damaged or broken.

3. ASTM-approved thermometers graduated in either degrees F or degrees C and specified in ASTM E 1. Specific thermometers recommended are the ASTM 14F (graduated in degrees F) or the ASTM 12C (graduated in degrees C). Thermometers are not required where thermohydrometers are used.

NOTE

Hydrometers and thermometers must be inspected periodically to ensure they are not cracked or that there are no separations of the mercury column.

4. Clear glass or clear plastic cylinders are preferred since accurate hydrometer readings can only be obtained with translucent plastic or metal cylinders when the sample level is at the top of the cylinder.
5. ASTM 250 Conversion Table.

E. API GRAVITY TEST PROCEDURE

1. Collect the sample in a clean hydrometer cylinder and place it in a vertical position in a location free from air currents. Allow 1-2 minutes for air bubbles to disappear. Remove any air bubbles that remain on the surface of the sample by touching them with the corner of a clean paper towel.
2. Obtain Temperature Reading
 - a) When Using Thermohydrometers
 - 1) Gently lower into the sample and, when it has settled, depress it about two scale divisions into the liquid and then release it. Gently spin the meter when releasing it. This will assist in bringing it to rest, floating freely away from the cylinder walls.
 - 2) Ensure it has come to rest and thermometer is showing a steady reading, read and record temperature of the sample to the nearest 0.5°C or 1°F.
 - b) When Using Plain Form Hydrometers
 - 1) Measure temperature with an approved thermometer first.
 - 2) Continuously stir the sample with the thermometer taking care that the mercury is kept fully immersed.

NOTE

The thermometer should not be completely removed from liquid to read temperature. Evaporation of liquid from the thermometer stem and bulb will lower the temperature and cause an incorrect reading.

- 3) When thermometer is showing a steady reading, read and record the temperature of the sample to the nearest 0.5°C or 1°F and remove thermometer.
3. Obtain hydrometer reading by reading the hydrometer to the nearest scale division and record the value. The correct hydrometer reading is that point on the hydrometer scale at which the principal surface of the liquid cuts the scale (Refer to Figure FSPM 03-13A) (p 3).

NOTE

The hydrometer must float freely to obtain a correct reading. It must not come to rest against the side or bottom of the cylinder during the test.

4. Correct observed hydrometer readings using appropriate temperature correction table (See Table FSPM 0313.a) (p 4) and report corrected gravity measurement.
5. When compared to previous measurements, if corrected API Gravity changes by one unit or more, the fuel is to be quarantined and the condition must be investigated and corrected. The Company must be notified per FSPM 03-01 anytime API gravity changes to unacceptable limits. Fueling or fuel receipt is not to be resumed from that source until the reason for the problem is found and corrected [Ref. FSPM 03-01].

CONTINUED ON FOLLOWING PAGE

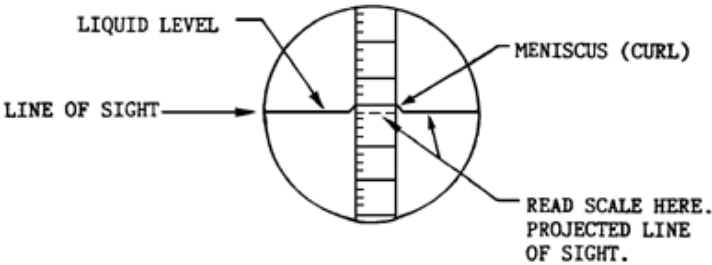
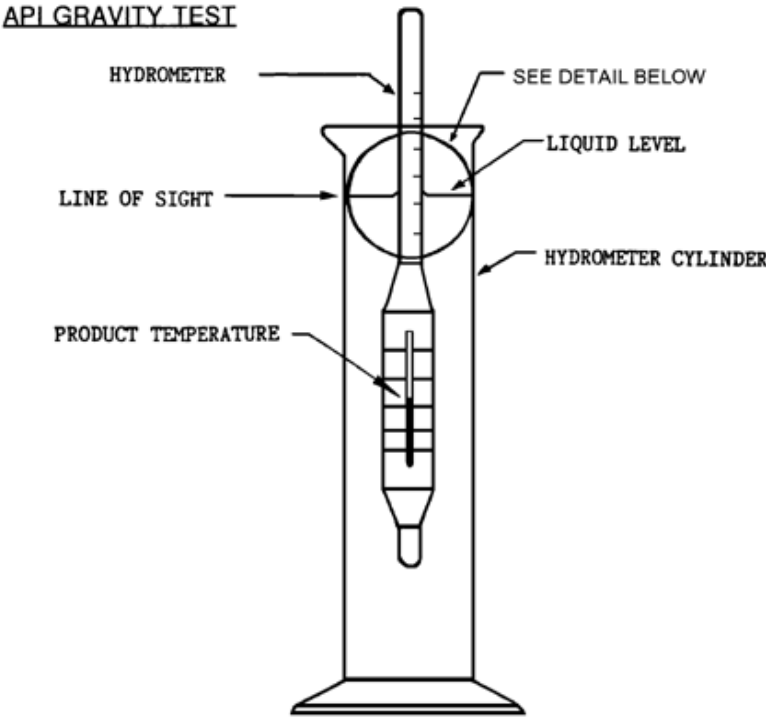

FIGURE FSPM 03-13A THERMOHYDROMETER (SHOWN)
(Plain Hydrometer is Similar)

CONTINUED ON FOLLOWING PAGE

Fueling and Servicing Procedures Manual

Table FSPM 0313.a: API Gravity Temperature Correction Table

API GRAVITY TEST

CORRECTION OF OBSERVED API GRAVITY TO STANDARD TEMPERATURE (60°F)

API GRAVITY UNITS AT OBSERVED TEMPERATURE (1)

TEMP ° F	45.0	45.5	46.0
75.0	43.6	44.1	44.6
75.5	43.6	44.1	44.6
76.0	43.6	44.0	44.5
76.5	43.5	44.0	44.5
77.0	43.5	44.0	44.4
77.5	43.4	43.9	44.4
78.0	43.4	43.9	44.3
78.5	43.3	43.8	44.3
79.0	43.3	43.8	44.3
79.5	43.2	43.7	44.2

(2) (3)

NOTE

(Only a small portion of ASTM 250 Conversion Table is shown.)

EXAMPLE: Fuel sample taken at temperature of 78.5°F has hydrometer reading of 45.5 units API Gravity.

- (1) Locate observed hydrometer reading in “API Gravity at Observed Temperature” column.
- (2) Read down this column to an observed temperature of 78.5°F.
- (3) The corrected API Gravity at 60°F is 43.8 units API Gravity.

END

FILTER VESSEL DIFFERENTIAL PRESSURE

CONTENTS

03-14.A	General	1
03-14.B	Policy	1
03-14.C	Fuel Filter Vessel Record	1

TABLES

Table FSPM 03-14.a	Instructions for Completing AE-FSPM-0314 Fuel Filter Vessel Record	1
Table FSPM 03-14.b	AE-FSPM-0314 Fuel Filter Vessel Record	3

A. GENERAL

1. The purpose of observing differential pressure across a filter vessel is to monitor the changing condition of the filter elements. Whenever fuel passes through a filter, a drop in pressure should occur. The difference in pressure between the inlet and outlet of the filter is known as differential pressure and is one of the more apparent indications of filter element conditions.

B. POLICY

1. The differential pressure reading shall be taken daily and recorded per FSPM 03-05 and 03-07. For accuracy, these checks should be undertaken when the flow rate is steady and as close as possible to maximum operating flow rate. Tests on individual pieces of equipment should be carried out at the same flow rate, if possible [Ref. FSPM 03-05, FSPM 03-07].
2. The filter vessel elements shall be replaced when the differential pressure exceeds the manufacturer's recommendation of 15 psi at 100% flow for filter separators and full flow monitors or when a sudden drop in differential pressure occurs under identical operating conditions.

NOTE

To determine the "corrected" filter differential pressure at less than 100% flow, use the appropriate manufacturer curve charts or the application titled "Differential Pressure Conversion Calculator" available at the [Tech Pubs website](#).

3. Verify proper operation of filter differential pressure gauge(s) in accordance with gauge manufacturer's procedures. The differential pressure gauge lines and valves should be checked to ensure they are not plugged or restricted. Replace or repair if found defective.

NOTE

Some direct reading gauges have small filters in their inlets. They must be cleaned or replaced periodically to assure proper operation.

C. FUEL FILTER VESSEL RECORD

1. The Fuel Filter Vessel Record (AE-FSPM-0314) ([p 3](#)) may be used to more readily identify trends in differential pressure.
2. At stations having more than one filter vessel at their fuel facility, the Fuel Filter Vessel Record should be used.
3. If used, it is to be completed daily as follows:

Table FSPM 0314.a: Instructions for Completing AE-FSPM-0314 Fuel Filter Vessel Record

ITEM	DESCRIPTION	RESPONSIBILITY
a)	Enter airport location as city, state and three letter city code.	Vendor
b)	Enter vendor's name.	Vendor
c)	Enter vessel manufacturer's name.	Vendor
d)	Enter date of last element change.	Vendor
e)	Enter model number.	Vendor
f)	Enter date of last interior inspection.	Vendor

Fueling and Servicing Procedures Manual

03-14
Page 2 of 3
07 Feb 17

Table FSPM 0314.a: Instructions for Completing AE-FSPM-0314 Fuel Filter Vessel Record

ITEM	DESCRIPTION	RESPONSIBILITY
g)	Enter fixed unit number.	Vendor
h)	Enter part numbers of elements installed.	Vendor
i)	Enter mobile unit number as applicable.	Vendor
j)	Enter rated flow in gallons per minute.	Vendor
k)	Enter date of last water defense check.	Vendor
l)	Indicate differential pressure by darkening circle for corresponding differential pressure. Connect dots to plot pressure differential.	Vendor
m)	Enter signatures of persons performing task.	Vendor
n)	Enter month and year.	Vendor

4. Disposition

- a) Retain on file for 24 months.

CONTINUED ON FOLLOWING PAGE

Fueling and Servicing Procedures Manual

Table FSPM 0314.b: AE-FSPM-0314 Fuel Filter Vessel Record

AE-FSPM-0314 03 Nov 09	FUEL FILTER VESSEL RECORD																																						
	AIRPORT _____	(a)	AGENCY _____	(b)																																			
	VESSEL MFG. _____	(c)	DATE LAST ELEMENT CHANGE _____	(d)																																			
	MODEL NO. _____	(e)	DATE LAST INTERIOR INSP. _____	(f)																																			
	FIXED UNIT NO. _____	(g)	P/N ELEMENTS INSTALLED _____	(h)																																			
	MOBILE UNIT NO. _____	(i)																																					
	RATED FLOW (Gallons per minute) _____	(j)	DATE WATER DEFENSE CHECK _____	(k)																																			
DIFFERENTIAL PRESSURE RECORD																																							
DIFFERENTIAL PRESSURE [psij]	20	0	0	0	0	0	0	0	0	0	0	0	0	0	0	0	0	0	0	0	0	0	0	0	0	0	0	0	0	0	0	0	0	0	0	0	0	0	
	19	0	0	0	0	0	0	0	0	0	0	0	0	0	0	0	0	0	0	0	0	0	0	0	0	0	0	0	0	0	0	0	0	0	0	0	0	0	
	18	0	0	0	0	0	0	0	0	0	0	0	0	0	0	0	0	0	0	0	0	0	0	0	0	0	0	0	0	0	0	0	0	0	0	0	0	0	0
	17	0	0	0	0	0	0	0	0	0	0	0	0	0	0	0	0	0	0	0	0	0	0	0	0	0	0	0	0	0	0	0	0	0	0	0	0	0	0
	16	0	0	0	0	0	0	0	0	0	0	0	0	0	0	0	0	0	0	0	0	0	0	0	0	0	0	0	0	0	0	0	0	0	0	0	0	0	0
	15	0	0	0	0	0	0	0	0	0	0	0	0	0	0	0	0	0	0	0	0	0	0	0	0	0	0	0	0	0	0	0	0	0	0	0	0	0	0
	14	0	0	0	0	0	0	0	0	0	0	0	0	0	0	0	0	0	0	0	0	0	0	0	0	0	0	0	0	0	0	0	0	0	0	0	0	0	0
	13	0	0	0	0	0	0	0	0	0	0	0	0	0	0	0	0	0	0	0	0	0	0	0	0	0	0	0	0	0	0	0	0	0	0	0	0	0	0
	12	0	0	0	0	0	0	0	0	0	0	0	0	0	0	0	0	0	0	0	0	0	0	0	0	0	0	0	0	0	0	0	0	0	0	0	0	0	0
	11	0	0	0	0	0	0	0	0	0	0	0	0	0	0	0	0	0	0	0	0	0	0	0	0	0	0	0	0	0	0	0	0	0	0	0	0	0	0
	10	0	0	0	0	0	0	0	0	0	0	0	0	0	0	0	0	0	0	0	0	0	0	0	0	0	0	0	0	0	0	0	0	0	0	0	0	0	0
	9	0	0	0	0	0	0	0	0	0	0	0	0	0	0	0	0	0	0	0	0	0	0	0	0	0	0	0	0	0	0	0	0	0	0	0	0	0	0
	8	0	0	0	0	0	0	0	0	0	0	0	0	0	0	0	0	0	0	0	0	0	0	0	0	0	0	0	0	0	0	0	0	0	0	0	0	0	0
	7	0	0	0	0	0	0	0	0	0	0	0	0	0	0	0	0	0	0	0	0	0	0	0	0	0	0	0	0	0	0	0	0	0	0	0	0	0	0
	6	0	0	0	0	0	0	0	0	0	0	0	0	0	0	0	0	0	0	0	0	0	0	0	0	0	0	0	0	0	0	0	0	0	0	0	0	0	0
	5	0	0	0	0	0	0	0	0	0	0	0	0	0	0	0	0	0	0	0	0	0	0	0	0	0	0	0	0	0	0	0	0	0	0	0	0	0	0
	4	0	0	0	0	0	0	0	0	0	0	0	0	0	0	0	0	0	0	0	0	0	0	0	0	0	0	0	0	0	0	0	0	0	0	0	0	0	0
	3	0	0	0	0	0	0	0	0	0	0	0	0	0	0	0	0	0	0	0	0	0	0	0	0	0	0	0	0	0	0	0	0	0	0	0	0	0	0
	2	0	0	0	0	0	0	0	0	0	0	0	0	0	0	0	0	0	0	0	0	0	0	0	0	0	0	0	0	0	0	0	0	0	0	0	0	0	0
	1	0	0	0	0	0	0	0	0	0	0	0	0	0	0	0	0	0	0	0	0	0	0	0	0	0	0	0	0	0	0	0	0	0	0	0	0	0	0
	0	0	0	0	0	0	0	0	0	0	0	0	0	0	0	0	0	0	0	0	0	0	0	0	0	0	0	0	0	0	0	0	0	0	0	0	0	0	0
	(i) DAY	01	02	03	04	05	06	07	08	09	10	11	12	13	14	15	16	17	18	19	20	21	22	23	24	25	26	27	28	29	30	31							
	SIGNATURE (m)																																						
MONTH/YEAR _____ (n)																																							
RETAIN THIS FORM ON FILE FOR 24 MONTHS																																							

BONDING CABLE CONTINUITY CHECK

CONTENTS

03-15.A	General	1
03-15.B	Procedures	1
03-15.C	Instructions	2

A. GENERAL

1. This section describes the equipment and procedures to check and test bonding cables. Safety of personnel, equipment and facilities is a primary concern.

B. PROCEDURES

1. Examine the full length of the cable. Check for breaks, fraying, kinking or any other physical damage. Replace cable immediately if any of these conditions exist.
2. Check the point of mechanical attachment of the cable to the reel (if used), facility bonding rod or truck chassis. Remove any corrosion found. Tighten attachment hardware if loose.
3. Check each spring-loaded bonding clamp for proper closure and general mechanical condition. Replace broken or questionable clamps immediately. Check for rust/corrosion and remove if found. Check the point of mechanical attachment of the cable to the clamp. Tighten attachment hardware if loose.
4. Using an equivalent tester to either a Continuity Tester N22T (Ray-O-Vac) or a calibrated Simpson model 260 Volt-OHM Meter, check the electrical continuity of each cable per paragraph "Instructions" ([p 2](#)).

NOTE

Electrostatic bonding system must have less than 25 ohms total resistance.

CONTINUED ON FOLLOWING PAGE

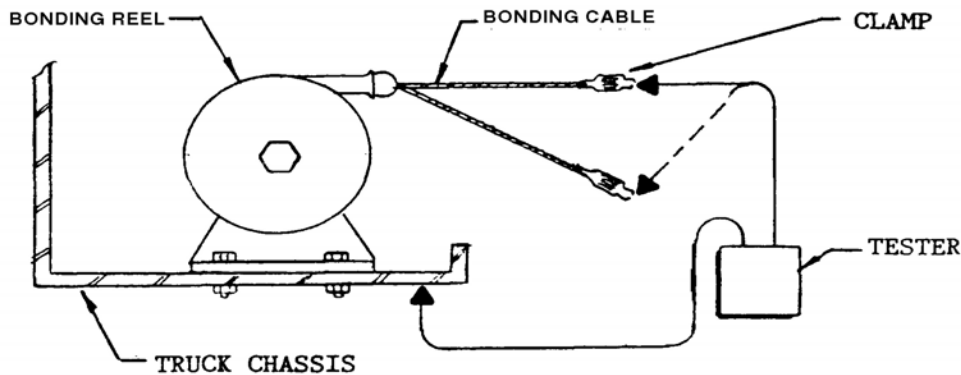
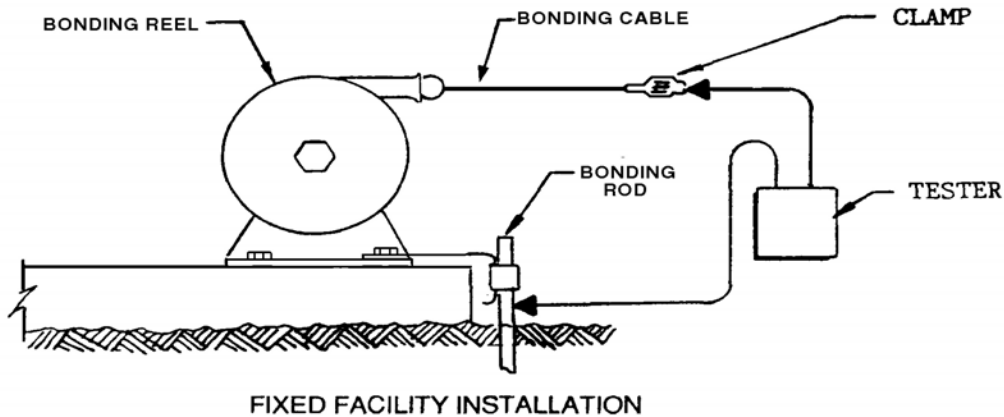

C. INSTRUCTIONS

CAUTION

Complete test in the open, never in a confined area, or anywhere there are confined fumes.

1. Connect tester leads as shown in Figure FSPM 03-15A.

CAUTION

Make sure the leads remain plugged into the back of the tester and do not switch on until the leads from the tester are connected to each end of the bond wire.

2. Turn ON tester and check continuity. If a continuity tester is used, continuity is indicated by a light. If a volt-ohm meter is used, set for resistance measurement 0 to 10,000 ohms. Acceptable continuity is indicated by a full-scale meter switch to 0 ohms.
3. When checking continuity on Y cables, check both legs.
4. Turn OFF tester and disconnect tester leads.

CAUTION

Turn OFF the switch before disconnecting the test leads from the bond wire.

5. If any cable fails to have continuity, replace or repair immediately.

END

WATER DEFENSE SYSTEM AUTOMATIC WATER SLUG AND DUMP SYSTEMS

CONTENTS

03-16.A	General	1
03-16.B	Description of Equipment	1
03-16.C	Precautions	1
03-16.D	Quarterly External Checks	2
03-16.E	Annual System Inspection and Test	2

A. GENERAL

1. This section contains a description of the two types of Water Defense Systems for filter vessel systems, and precautions that should be observed to ensure proper operation of the systems.
2. Systems are to be checked on a quarterly basis per FSPM 03-05 and 03-07 [Ref. FSPM 03-05, FSPM 03-07].
3. Procedures for testing these systems are to be accomplished per manufacturer instructions. For systems where manufacturer's procedures are not available, guidance may be obtained from ASTM MNL5.
4. Checking of Water Defense Systems is not required on filter vessels that have been converted to water adsorbing elements.

B. DESCRIPTION OF EQUIPMENT

1. A flow control valve (or slug valve) is installed in a system to stop fuel flow when water reaches a predetermined level in the filter/separator. This system may also include an automatic water dump valve. The different kinds of systems that may be installed are described below.
2. Float Operated System
 - a) This system is actuated by a signal from a float with a sealed air and fluid chamber which, when properly balanced, will sink in fuel and float in water. The float remains in the downward position, permitting fuel flow, until enough water accumulates in the sump to raise the float.
 - b) As the float rises, it re-positions a pilot valve or operates an electrical switch either of which will stop fuel flow. In order to restart fuel flow, the operator must manually drain the accumulated water from the sump, allowing the float to return to the downward position.
 - c) In some Float Operated Systems, an additional function is provided whereby, at an intermediate float position, the pilot valve (or an additional electrical switch) is actuated which opens a water dump valve to automatically drain the accumulated water. At the higher level, the flow is stopped as noted previously. An automatic water drain valve does not discharge all the water from the sump. Complete water removal must be ensured to prevent microbiological growth.
3. Electric Exposed or Sealed-Probe-Operated System
 - a) This type of system consists of an electric probe installed in the filter/separator sump which actuates a relay system to stop fuel flow when sufficient water accumulates. Water must be drained off manually before fuel flow can resume.
 - b) In some stationary Probe-Operated Systems, an additional function is provided whereby, at an intermediate water level in the sump, a different set of contacts within the probe are actuated. This opens a water dump valve to automatically drain any accumulated water. At the higher level, the flow is stopped as noted previously. An automatic water drain valve does not discharge all the water from the sump. Complete water removal must be ensured to prevent microbiological growth.

C. PRECAUTIONS

1. Use the manual water drain valve for daily or more frequent drainings, even when an automatic water drain valve is installed. It should be emphasized that these automatic drain valves **do not** operate until there is a substantial quantity of water in the sump of the unit and, therefore, do not replace the requirement for manually draining all water from these sumps. (An automatic water drain valve does not discharge all the water from the sump.) Good housekeeping procedures prescribe complete removal of the sump water to prevent microbiological growth.
2. Never use city, or other pressurized Water Supply Systems, for Float System Tests. The fuel pressure can be greater than the pressurized water supply pressure, and fuel could be forced into the Potable Water System, contaminating the system. Additionally, there is no positive means to verify how much water actually has been put into the sump.

3. When testing Mobile Float Systems, always inject a measured amount of water, and never more than one gallon. The same amount of water should be recovered after completion of the test.
4. Be sure the vent port from the pilot valve (float control valve) is unobstructed. Sometimes this vent is plugged during shipment to prevent dirt or debris from getting into the pilot valve assembly. If the plug is not removed prior to system operation, improper operation of the fuel flow control valve and/or automatic drain valve will occur.
5. Ensure that the pilot valve (float control valve) is installed correct side up. If mounted upside down, the fuel flow control valve (slug/discharge valve) will operate improperly.
6. A leaking automatic water drain valve should be repaired immediately. Do not install caps or plugs to stop a leaking water drain valve as this will affect the operation of the water slug valve.
7. After testing the float and pilot assembly, ensure that all ports are free of water before reinstallation.
8. Be sure to provide adequate means for collecting the discharged fuel when using the manual tester on a float or probe-operated pilot valve which activates an automatic water dump valve.
9. Water shall never be injected into mobile equipment water defense systems while fueling an aircraft.

WARNING

The manual tester on the float pilot valve only checks the operation of the pilot valve assembly. It does not check whether or not the float will float in water.

D. QUARTERLY EXTERNAL CHECKS

1. Externally check for satisfactory operation of water defense system by mechanically raising the float or float ballast on float-type systems, or injecting water into the probe on probe-type systems. The system(s) may also be checked by injecting water into the filter sump(s).
2. Repair any system deficiencies before returning equipment to service.

E. ANNUAL SYSTEM INSPECTION AND TEST

1. Check for satisfactory operation of float-type Water Defense Systems by verifying proper system shutdown when the float is in the raised position, and confirm buoyancy of floats that are not equipped with external ballasts.
2. Check for satisfactory operation of probe-type Water Defense Systems by injecting water into the probe.

NOTE

Check probe assemblies in probe-type systems for contaminants, which may have accumulated on the outside of the probe. Clean the probe exterior according to manufacturer's instructions. This will ensure that the probe will be sensitive to changes in resistivity and properly signal the presence of water in the filter sump. If the probe is insulated by contaminants, it may not properly activate the Water Defense System.

3. Repair any system deficiencies before returning equipment to service.

END

Fueling and Servicing Procedures Manual

FUEL STORAGE TANK INSPECTION AND CLEANING

CONTENTS

03-17.A	General	1
03-17.B	Storage and Reclamation Tank Inspection and Cleaning Record	1
03-17.C	Disposition	1

TABLES

Table FSPM 03-17.a	Instructions for AE-FSPM-0317 Storage and Reclamation Tank Inspection and Cleaning Record	1
Table FSPM 03-17.b	AE-FSPM-0317 Storage and Reclamation Tank Inspection and Cleaning Record	2

A. GENERAL

1. Storage tanks shall be inspected at least every 12 months. Check for buildup of sediment or evidence of microbial growth. If inspection reveals microbial growth or buildup of sediment exceeding 1/10 of the area of the tank bottom surface, cleaning shall be accomplished.
2. The following should be considered guidelines for cleaning only. Actual cleaning procedures will differ between locations.
 - a) Jet fuel storage tanks should be cleaned with high pressure water only. Under no circumstances should solvents, chemicals or detergents be used.
 - b) After cleaning with water, use squeegees and lint free mops to dry the tank surfaces. Assure removal of all free water, and allow tank to dry through natural ventilation as long as practicable.
 - c) If the tank has internal epoxy coating, inspect coating for evidence of chipping, flaking or other deterioration.
 - d) Maintain a record of tank inspection and cleaning on the form provided (AE-FSPM-0317). For convenience, it is also suggested that the inspection and cleaning dates be stenciled on the tank manhole cover.

CAUTION

Entry of fuel storage tank requires specialized equipment and personnel training, and must be accomplished in accordance with local, state and federal occupational safety regulations. The vendor should not attempt entry of a storage tank unless the required equipment is on hand and the required training of personnel has been administered.

B. STORAGE AND RECLAMATION TANK INSPECTION AND CLEANING RECORD

Table FSPM 0317.a: Instructions for AE-FSPM-0317 Storage and Reclamation Tank Inspection and Cleaning Record

ITEM	DESCRIPTION	RESPONSIBILITY
1.	Enter airport location as city and state.	Vendor
2.	Enter vendor's name.	Vendor
3.	Enter tank number.	Vendor
4.	Enter date inspected.	Vendor
5.	Indicate condition and action by checking off the applicable codes.	Vendor
6.	Enter signature of person performing check.	Vendor

C. DISPOSITION

1. Retain form on file indefinitely.

CONTINUED ON FOLLOWING PAGE

Fueling and Servicing Procedures Manual

Table FSPM 0317.b: AE-FSPM-0317 Storage and Reclamation Tank Inspection and Cleaning Record

AE-FSPM-0317 04 May 10										
STORAGE AND RECLAMATION TANK INSPECTION AND CLEANING RECORD										
AIRPORT _____(1)_____						FACILITY _____(2)_____				
TANK NO. _____(3)_____										
DATE INSPECTED	CONDITION							ACTION		SIGNATURE
	1	2	3	4	S	R	M	CL	NC	
(4)			(5)							(6)
CONDITION CODES: 1 = CLEAN 2 = TRACE 3 = MODERATE 4 = HEAVY S = SEDIMENT R = RUST M = MICROBIAL GROWTH ACTION CODES: CL = CLEANED NC = NOT CLEANED										
REMARKS										
RETAIN THIS FORM ON FILE INDEFINITELY										

END

WATER SEPARATOR TEST (MICROSEP)

CONTENTS

03-18.A General 1

A. GENERAL

1. Fuel containing little or no surfactant has excellent water separation characteristics. Fuel containing significant amount of surfactant has very poor water separation characteristics. The better the water separation rating, the more effective system filtration equipment will be in removing free water.
2. The water separator test provides a field method for determining water separation characteristics of jet fuel. Detailed instructions for performing the test are contained in ASTM Method D-3948. A copy of the method may be obtained from the American Society for Testing and Materials, 1916 Race Street, Philadelphia, PA 19103.
 - a) The test is particularly useful in monitoring clay treatment vessel performance. Tests are normally performed on samples from the upstream and downstream sides of the vessel and the results compared. Assuming a relatively low rating upstream (e.g. 70), the downstream result should be 90 or higher if the clay is active. No improvement or a worsening of the rating on the downstream side of the vessel are indications of spent clay. In a well maintained Fuel Handling System equipped with a clay treatment vessel, water separation ratings are normally in the range of 90 to 100.
 - b) The operator should be aware of the fact that this is a very sensitive test. Erroneous results can be obtained if improper sample containers are used. This is especially true with new unlined metal containers.
3. Water Separator Test is accomplished when a new, modified, repaired Hydrant Fuel System or portion thereof is placed into service.

END

FILTER ELEMENT REPLACEMENT CRITERIA

CONTENTS

03-19.A	General	1
03-19.B	Element Replacement Criteria and Frequency	1
03-19.C	Coalescer Element Time Extension	1

A. GENERAL

1. The following are replacement criteria for elements and time extension procedure of coalescer elements.

B. ELEMENT REPLACEMENT CRITERIA AND FREQUENCY

1. Coalescer elements must be replaced when:
 - a) Filter Membrane (Millipore) Test indicates elements are not performing to acceptable levels [Ref. FSPM 03-11].
 - b) Differential pressure exceeds 15 psi or there is a sudden drop in differential pressure [Ref. FSPM 03-14].
 - c) Continuous sump samples indicate surfactants, microbial or solid contaminants [Ref. FSPM 03-10].
 - d) Element has been in service for 12 months.

NOTE

This time limit may be extended per paragraph "Coalescer Element Time Extension."

- e) Free water detection test indicates elements are not performing to acceptable levels [Ref. FSPM 03-12].
2. Teflon-coated separator elements
Teflon-coated separator element's life can be extended indefinitely as long as element is cleaned and inspected according to manufacturer's instructions.
 3. Paper separator elements
Paper separator elements must be replaced whenever the coalescer elements are replaced. Maximum service life of a paper separator element is two years.
 4. Full Flow Monitor Elements
Full flow monitor elements must be replaced when:
 - a) Filter Membrane (Millipore) Test indicates elements are not performing to acceptable levels [Ref. FSPM 03-11].
 - b) Differential pressure exceeds 15 psi or there is a sudden drop in differential pressure [Ref. FSPM 03-14].
 - c) Chemical water detection test indicates a positive reading of more than 15 ppm [Ref. FSPM 03-12].
 - d) Continuous sump samples indicate surfactants, microbial or solid contaminants [Ref. FSPM 03-10].
 - e) Element has been in service for 12 months.

C. COALESCER ELEMENT TIME EXTENSION

1. Vendors may request time extensions for filter elements as an Alternate Procedure per FSPM 02-01 [Ref. FSPM 02-01].
2. Extensions will be considered for approval if a documented element test program is submitted for review prior to conducting the 12 months element replacement.
3. Approval will be granted or denied via Alternate Procedures method FSPM 02-01 [Ref. FSPM 02-01].

END

HYDRANT SYSTEMS CLEANING STANDARDS – FUEL SYSTEM PIPING

CONTENTS

03-20.A	General	1
03-20.B	Policy	1
03-20.C	Flushing Into Tank Trucks	2
03-20.D	Acceptance Specifications	2

A. GENERAL

1. Before a new, modified, repaired Hydrant Fuel System, or portion thereof is placed into service, the vendor shall:
 - a) Notify Company MSC representative per FSPM 03-00 prior to publication and release of construction documents [Ref. FSPM 03-00].
 - b) Ensure all affected piping is flushed and tested to ensure cleanliness before aircraft fueling is permitted.
2. The following policy statements are considered to be minimum requirements.

B. POLICY

1. Company MSC Representative:
 - a) Shall pre-approve flushing procedures to a desired flow rate of 10 feet per second.
 - b) Determine and accept system cleanliness before aircraft fuel servicing is permitted.
2. Vendor shall ensure:
 - a) Product used for flushing meets ASTM D-1655/DERD 2494, latest revision, specs for kerosene Jet A/A-1 type aviation grade turbine fuels [Ref. FSPM 03-01].
 - b) Flushing procedure is accomplished to a desired flow rate of 10 feet per second.
 - c) No flushing is done through hydrant pit valves.
 - d) Any contracted work accomplished is performed as indicated in **e)** below.
 - e) Installing Contractors are to:
 - 1) Accomplish flushing procedures as specified.
 - 2) Where possible, install temporary piping connections to form a Closed Loop Piping System and Flush System by means of recirculation.
 - 3) Provide all temporary cross connections or special fabrication of adapters required.
 - 4) Provide additional temporary pumps and filters if required to provide minimum flow velocity.
 - 5) Provide all filtration media required for the system flush.
 - 6) Upon completion of flush, install new coalescerants in filter/separators. Separator elements are to be inspected and replaced if damaged.
 - 7) If flushing into tank trucks, provide any temporary manifolds plus sufficient number of single compartment tank trucks and hoses to allow the desired flow rates to be achieved in a safe manner. Hoses and couplings are to be aircraft type with a minimum 150 lb. rating and must be hydrostatically tested. Recommended 4" hose size to achieve flow capacities during flush.
 - 8) Ensure all general service valves and adapters are in place throughout the system flush.
 - 9) Remove control valves and metering assemblies prior to initiating flush.
 - f) At a minimum, two tests meeting acceptance specifications in paragraph "Acceptance Specifications" are done after flushing to ensure piping cleanliness.
 - 1) Test samples are drawn immediately ahead of filtration on Closed Loop Recirculation Systems, immediately ahead of storage tanks in receiving manifold on Recirculation Systems returning flushed fuel to tankage, or immediately ahead of transport trucks on Single Line Systems.
 - 2) If specifications are not met, the system being flushed must be displaced with clean fuel prior to taking the second test.
 - g) If tank trucks are used for flushing, ensure the requirements in paragraph "Flushing Into Tank Trucks" are met.

C. FLUSHING INTO TANK TRUCKS

CAUTION

All electrical and motorized equipment in area should be shut down in case of a mishap or fuel spill. For safety, all persons not involved in the flushing operation must be kept a minimum of 100 feet away from tank trucks and hydrant pits used in the flushing operation.

1. Tank truck internal valves should be safety-wired in an open position.
2. All quick release-type couplings are to be safety-wired when coupled to the bottom load receptacle and hydrant adapter.
3. Hoses are to be secured in a manner to prevent whipping during flush.
4. Bond truck to Hydrant System piping.
5. Start product flow slowly before reaching flushing velocity to check for leaks and system tightness.
6. Fire extinguishers are to be in place in case of emergency.
7. Location of personnel:
 - a) One person per each tank truck to monitor fuel level in tank.
 - b) One person at each hydrant pit to control fuel flow into tank truck.
 - c) One person at main pump control station to shut down pumps in emergency.
 - d) One person at nearest terminal EFS station to shut down pumps in emergency.
 - e) One person manning fire extinguisher(s).
 - f) One person removed from manual tasks in command of flushing operation.

D. ACCEPTANCE SPECIFICATIONS

1. Visual – All fuel samples must be Clear-and-Bright, using the White Bucket Test [Ref. FSPM 03-10].
2. Solids – Particle Assessment – “B” Scale @ One Gallon Sample Membrane Color – #3 Rated Wet @ One Gallon Sample [Ref. FSPM 03-11]

NOTE

If color rating exceeds the above limits or is in dispute, a matched weight gravimetric rating not to exceed 0.5 mg./gallon shall govern.

3. Water – 15 ppm Maximum [Ref. FSPM 03-12]
4. Water Separation (Microsep) Rating – 85 Minimum [Ref. FSPM 03-18]

END

Fueling and Servicing Procedures Manual

FUEL TRUCK TANK CLEANING

CONTENTS

03-21.A	General	1
03-21.B	Policy	1
03-21.C	Acceptance Specifications	1

A. GENERAL

- Whenever a fuel truck is returned to service after repair or overhaul of the tank or plumbing, the vendor shall:
 - Notify Company MSC representative per FSPM 03-00 prior to publication and release of repair or overhaul documents [Ref. FSPM 03-00].
 - Ensure all affected piping is flushed and tested to ensure cleanliness before aircraft fueling is permitted.
- Company MSC representative shall determine and accept system cleanliness before aircraft fuel servicing is permitted.
- The following policy statements outline the minimum requirements that must be observed in order to eliminate the possibility of fuel contamination.

B. POLICY

- Vendor shall ensure:
 - Product used for flushing must meet ASTM D-1655/DERD 2494, latest revision, specs for kerosene Jet A/A-1 type aviation grade turbine fuels [Ref. FSPM 03-01].

NOTE

If water softener has been used in cleaning the tank or lines, the tank truck and plumbing lines are to be thoroughly rinsed with clean water until it runs clear.

- Flow check after filling with fuel to ensure that plumbing is free of contamination.

CAUTION

Any time water has been used to test tank or lines – flow an adequate quantity of fuel through the Vehicle System before fueling an aircraft, to be sure all water is removed.

- At a minimum, two tests meeting the acceptance specifications listed in the following paragraph are done at water drains and sumps after flushing to ensure piping cleanliness. If specifications are not met, the system being flushed must be displaced with clean fuel prior to taking the second test.

C. ACCEPTANCE SPECIFICATIONS

- Visual – All fuel samples must be Clear-and-Bright, using the White Bucket Test [Ref. FSPM 03-10].
- Solids – Particle Assessment – “B” Scale @ One Gallon Sample Membrane Color – #3 Rated Wet @ One Gallon Sample [Ref. FSPM 03-11]

NOTE

If color rating exceeds the above limits or is in dispute, a matched weight gravimetric rating not to exceed 0.5 mg./gallon shall govern.

- Water – 15 PPM Maximum [Ref. FSPM 03-12]
- Water Separation (Microsep) Rating – 85 Minimum [Ref. FSPM 03-18]

END

FUELING SELF-AUDIT PROCEDURES

CONTENTS

04-00.A	General	1
04-00.B	Responsibility and Authority	1
04-00.C	Procedures	2

A. GENERAL

1. Self-audits of jet fuel storage facilities, mobile refueling units and Into-Plane fueling operations are to be performed at all Company stations as described in this section.

NOTE

The term "vendor" used in the Envoy Fuel Self-Audit Checklist is inclusive of contract and/or internal providers of fuel services.

2. Envoy Fuel Self-Audit Checklist is to be used for station fueling self-audits at stations which service AA and Envoy aircraft. An AA Fuel Self-Audit is also acceptable.
3. After completion, if separate sheets are used or a report is developed, they also become part of the audit.
4. The Envoy Fuel Self-Audit Checklist and Fuel Self-Audit Finding Discrepancy and Response Sheet instructions are maintained on the [Envoy MSC website](#) (See paragraph "Procedures").
5. Station Fuel Self-Audit Checklist has been developed into the following elements:
 - Aircraft Servicing Observation
 - Fuel Servicing Equipment Inspection
 - Jet Fuel Servicing Record Review
 - Personnel Qualification Records Review
 - Fueling Equipment Record Review
 - Fuel Storage Facility Review
 - Storage Facility Record Review
6. These elements have been placed in the above order to assist in the ease and facilitation of the fuel self-audit. It is recommended that the fuel self-audit be completed in this order but the elements may be done individually.

B. RESPONSIBILITY AND AUTHORITY

1. At cities where Envoy is responsible for the station's operation, the General Manager or highest ranking Field Services representative is responsible for ensuring the fuel self-audit is accomplished and on file.
2. At cities where a vendor or contracted company are responsible for the station's operation, the vendor/contractor's General Manager or their highest ranking representative is responsible for ensuring the fuel self-audit is accomplished on time and filed.
3. At joint Envoy/American Airlines stations, Envoy accepts the American Airlines Fueling Self-Audit conducted by American Airlines.

NOTE

Envoy accepts AA Fuel Audit Policies and Procedures. MSC may accept fuel audits performed by AA at joint stations upon satisfactory review of AA fuel audit.

4. When there is a fuel vendor change, the aforementioned identified person is responsible for ensuring the station fuel self-audit is performed within three months of the change of fuel vendor. This applies to both Into-Plane and Fuel Storage vendors' changes. Disposition will be handled as outlined in paragraph "Disposition of Fuel Self-Audit Checklist."
5. When a fuel vendor change or fuel vendor name change occurs, the aforementioned identified person is responsible for notifying the DMSC by email (msc.support@aa.com) or by telephone at (972/ics) 374-9364.
6. Persons identified above are responsible for ensuring that any findings resulting from the station fuel self-audit are corrected or resolved within 30 days. Vendors being audited are responsible for correcting any self-audit findings.

C. PROCEDURES

1. Frequency of Fuel Self-Audit and Checklist Use

- a) **The fuel self-audit must be completed in the second quarter of each calendar year** (See **NOTE** below for seasonal and/or temporary operation). At management discretion, self-audits may be performed more frequently if conditions warrant.

NOTE

New, seasonal and/or temporary operation stations must complete a fuel self-audit within 30 days of opening or re-opening.

- b) Fuel self-audits are completed through the use of the appropriate checklists located at the [Envoy MSC website](#). Corrective action items must be completed before an audit can be considered closed. Stations which can not access this website shall contact MSC by telephone (972) 374-9376 or email (msc.support@aa.com) to obtain the checklist required to perform this audit.
- c) Findings are to be entered on the Envoy Fuel Self-Audit Finding Discrepancy and Response Sheet that is provided with the checklist, and forwarded to the vendor to provide their written response (make as many copies of the sheet as needed to record findings).
- d) The last two completed fuel self-audits are to be maintained locally. When another fuel self-audit has been completed and closed, the oldest audit may be discarded. The closed fuel self-audit must include documentation of the corrective action items.

2. Disposition of Fuel Self-Audit Checklist

- a) Findings should be resolved at the local station level whenever possible. This requires coordination between the responsible local station General Manager and the fuel vendor. If findings require specialized fuel handling experience, and can not be resolved locally, contact the DMSC by telephone at (972) 374-9364 or email (msc.support@aa.com).
- b) Items affecting service or safety must be corrected immediately and the actions taken recorded on the Envoy Fuel Self-Audit Finding Discrepancy and Response Sheet.

NOTE

Immediately forward a copy of the response sheet to the DMSC (via electronically transmittal) to ensure prompt review and coordination with SOC as required.

- c) For findings that do not affect service or safety, the fuel vendor representative is to submit a written response on the Envoy Fuel Self-Audit Finding Discrepancy and Response Sheet to the responsible Station Manager within 30 days of the fuel self-audit.
- d) The responsible Station Manager is required to follow up as necessary to ensure any corrective action plans have been implemented and the fuel vendor has corrected the findings.

NOTE

If there are no findings, submit only the Envoy Fuel Self-Audit Finding Discrepancy and Response Sheet marked "No Findings."

- e) After resolution of all findings, the completed Envoy Fuel Self-Audit Checklist, Finding Discrepancy, Response Sheets, and any other associated documentation shall be sent to Envoy MSC Office via fax (972) 374-9215 or email (msc.support@aa.com) and to Fuel Vendor Representative.
- f) Original documents are to be retained in the local station file.

3. Analysis and Reporting

- a) The CASS Analyst will review and analyze all submitted Envoy Fuel Self-Audit Finding Discrepancy and Response Sheets to identify and report system-wide failure trends.
- b) When all response sheets have been submitted and analyzed, the DMSC will report the self-audit analysis to the DMO, the Director SOC and the VP Field Services.

NOTE

At cities where Envoy is responsible for the station's operations, the General Manager or highest-ranking Field Services representative is responsible for ensuring the Fuel Self-Audit is accomplished and filed on time.

4. Training:

- a) Fuel Self-Audit training is now online. The training course code is MTX0487. The person required to perform the self-audit must take this WBT prior to conducting the audit if he has not received training previously.

END

EMB 145 FUEL SERVICING

CONTENTS

05-00.A	General	1
05-00.B	Fuel Specifications	1
05-00.C	Fuel Capacities	1
05-00.D	Fueling Precautions	2
05-00.E	Bonding Points	2
05-00.F	General Procedures – Fueling	3
05-00.G	Procedures – Pressure Refueling	4
05-00.H	Procedures – Gravity Refueling	6
05-00.I	General Procedures – Defueling	7
05-00.J	Procedures – Pressure Defueling	7
05-00.K	Procedures – Gravity Defueling	8

TABLES

Table FSPM 05-00.a	Approved Fuels	1
Table FSPM 05-00.b	Fuel Tank Capacities	2

A. GENERAL

- Fueling can be accomplished by pressure or gravity method utilizing external or battery power.
- When a problem is encountered during fuel servicing, it must be investigated and corrected. These may include spills/leaks, valve or indication problems, malfunctioning equipment, damage, etc. For example, fuel spillage through an aircraft fuel tank vent during pressure refueling may indicate a malfunction of a tank valve or over-pressurization of a tank due to malfunction of fueling equipment.
- Observe “Precautions Required for Aircraft Servicing” as contained in FSPM 02-02.
- Access to the fuel control panel and pressure fueling adapter are through the access door 191BR, on the right side of the fuselage. See Figure FSPM 05-00C, Detail A.

B. FUEL SPECIFICATIONS

- Approved Fuels include the following:

Table FSPM 0500.a: Approved Fuels

GROUP	SPECIFICATION	COMMERCIAL PRODUCT	SUPPLIER / MANUFACTURER
Engine Fuel	CNP-08	QAV1	Local Supplier
	ASTM D1655	JET A, JET A-1	Local Supplier
	MIL-T83133A	JP8	Local Supplier
	GB 6537-94	No.3 Jet Fuel	Local Supplier
	GOST 10227-86	TS-1	Local Supplier

NOTE

If using Fuel-System Icing Inhibitors (FSII), the following can be used: Ethylene Glycol Monomethyl Ether (EGME), which meets the requirements of MIL-I-27686 (NATO S-748), ASTM-D-4171 or GOST 8313, or Di-Ethylene Glycol Monomethyl Ether (Di-EGME), which meets the requirements of MIL-I-85470A. Follow the fluid manufacturer’s specifications to find the additive proportions.

C. FUEL CAPACITIES

- The following table shows usable fuel tank capacities. Fuel weight is fuel with an API density of 42.7 at 60° F; weight will vary with fuel density.

NOTE

The following information is applicable to EMB 145LR/LU and EMB 135LR/KL.

Fueling and Servicing Procedures Manual

Table FSPM 0500.b: Fuel Tank Capacities

LOCATIONS	U.S. GALLONS	LITERS	POUNDS
Left Wing	844.9	3,193	5717
Right Wing	844.9	3,193	5717
Total	1689.8	6,386	11434

D. FUELING PRECAUTIONS

1. Observe the precautions in Figure FSPM 05-00A during fueling/defueling.

FIGURE FSPM 05-00A

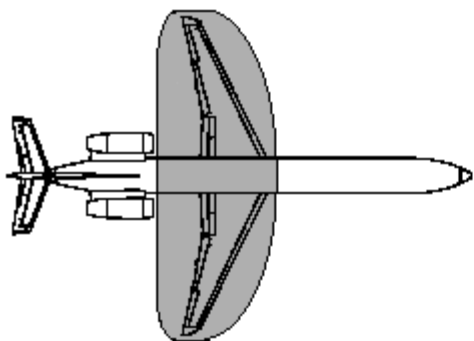

KEEP THE SHADED AREA FREE OF VEHICLES AND EQUIPMENT DURING PRESSURE REFUELING OPERATION.

E. BONDING POINTS

1. Bonding points are shown in Figure FSPM 05-00B.

CONTINUED ON FOLLOWING PAGE

FIGURE FSPM 05-00B: SERVICING BONDING POINTS

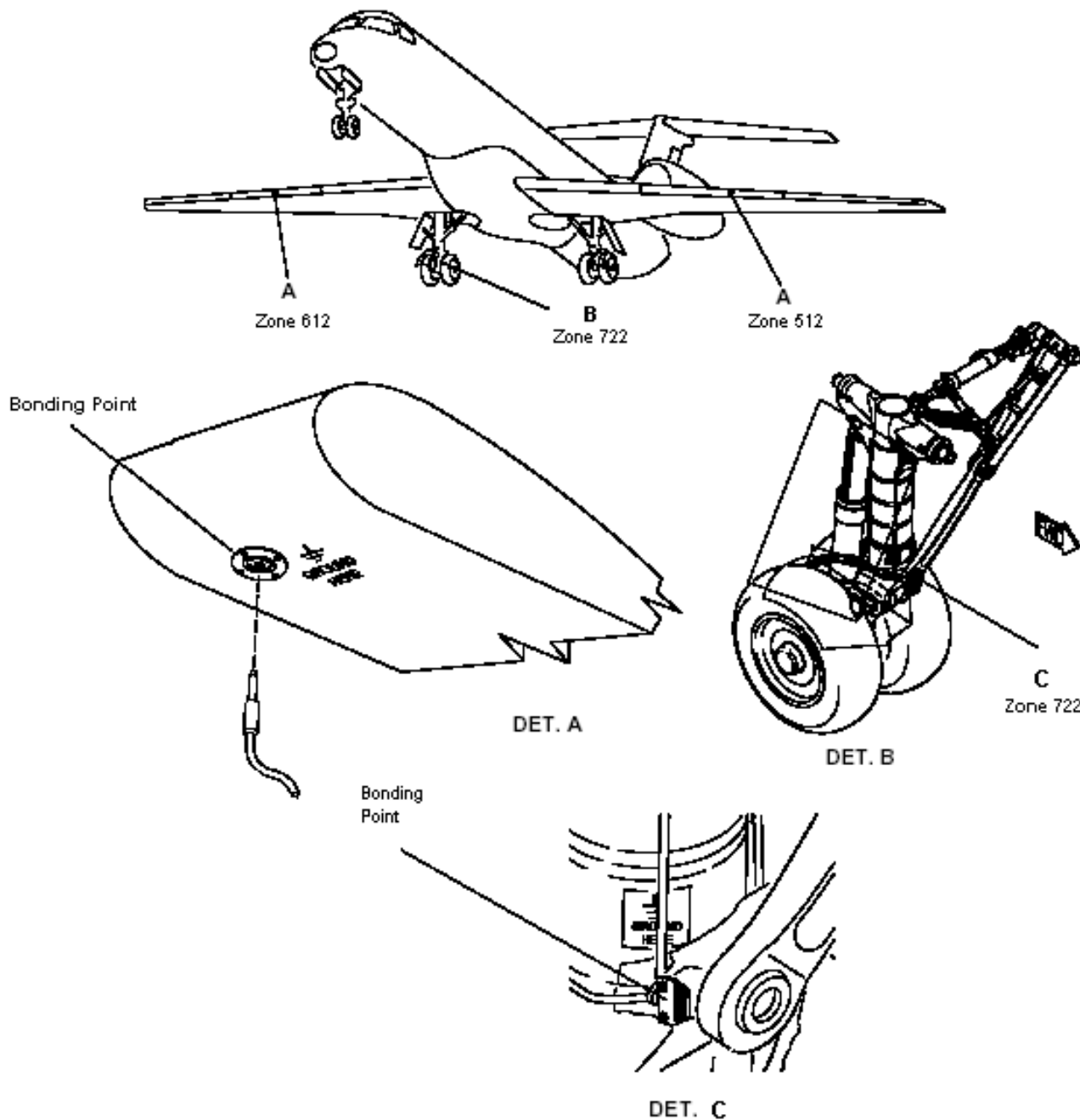

CAUTION

During all fueling operations, make sure aircraft is electrically bonded.

F. GENERAL PROCEDURES – FUELING

1. Envoy considers all aircraft ground time (with or without passengers on board) a fueling/defueling period.
2. The fueller is responsible for the fueling operation. The fueller's employer is responsible for ensuring that all employees who fuel Envoy aircraft:
 - a) Have been properly trained.
 - b) Have a clear understanding of all required communication procedures and methods.
 - c) Provides notification to the flight crew or other qualified personnel when a hazardous condition or situation has been determined to exist.

- d) Have the ability to execute such procedures in an expeditious manner should a dangerous situation develop.
3. A suitable method of notification to the flight crew or other qualified persons may include use of the aircraft inter-communication system, direct person-to-person contact or other methods that ensure direct and timely communication.
4. If a fuel spill occurs at any time, use the procedures in FSPM 02-05.
5. Station Personnel will coordinate with the Flight Crew about the decision to deplane.
6. Flight Attendants will be stationed in the aircraft cabin as outlined in the Envoy Inflight Procedures Manual.
7. When fueling with passengers on board, the jetbridge or passenger loading stairs must be positioned at an entry door of the airplane and the door will remain open.
8. Pilots are not required to be present during fueling with or without passengers on-board, however, if present must ensure ability to communicate is maintained by any suitable means between the fuel vendor and qualified on-board personnel.
9. Fueling equipment shall not be positioned to obstruct aircraft emergency exit routes (including evacuation chutes) with or without passengers on board.
10. Smoking is not permitted on the aircraft or on the ramp at any time.

G. PROCEDURES – PRESSURE REFUELING

CAUTION

If the Pressure Refuel/Defuel system or the Fuel Quantity gages on the refuel panel are on MEL, Gravity/Overwing refueling must be accomplished.

1. Ensure that the nose landing gear wheels are properly chocked. Refer to FSPM 02-03.
2. Statically bond the aircraft.

NOTE

Make all bonding connections between the fuel source, aircraft, and fuel nozzle [Ref. FSPM 02-04 and any local regulatory authority requirements].

3. Energize the aircraft with external DC Power Supply.

NOTE

If the external DC Power Supply is not available, set the power selection switch to the battery position, on the refueling panel.

4. Open access door 191BR. See Figure FSPM 05-00C ([p 5](#)).
5. Make sure that the:
 - a) REFUELING lights for the LH and RH tanks are OFF.
 - b) DEFUELING light is OFF.
 - c) SELECTED quantity indicator shows zero.
6. Set the indicator to the necessary fuel quantity.

WARNING

Ensure that maximum fuel imbalance limitations are observed. Do not exceed 800 lb. (362.88 kg) imbalance between the main tanks when refueling, as the aircraft may move/shift and cause injuries to personnel and/or damage to equipment.

7. Remove the protection cover from the pressure refueling adapter.
8. Connect the fuel nozzle to the pressure refueling adapter.
9. Pressurize the system (35 – 45 psig).
10. Make sure that the REFUELING lights related to the LH and RH tanks come ON (CLOSED or CLSD, as applicable) and the refueling flow stops.
11. Set the REFUELING switch to the OPEN position and make sure that the REFUELING lights related to the LH and RH tanks go OFF.

12. (For aircraft with HLEIS) If one or more than one of the STOP RFL lights come(s) on, immediately remove the fuel pressure that comes from the refueling source and stop the refueling procedure.
13. Make sure that the REFUELING lights related to the LH and RH tanks come ON (CLOSED), when the set fuel quantity is reached.
14. Set the REFUELING switch to the CLOSED position.
15. Remove the fuel nozzle from the pressure fueling adapter.
16. Install the protection cover to the pressure refueling adapter.
17. De-energize the aircraft.

NOTE

If the POWER SELECTION switch at the BATTERY position was used, set it back to the NORMAL position and close the switch guard.

18. Remove the bonding cable from the aircraft.

WARNING

Make sure that all the switch guards are at the closed position on the refueling panel.

19. Close access door 191 BR.

FIGURE FSPM 05-00C: PRESSURE REFUELING

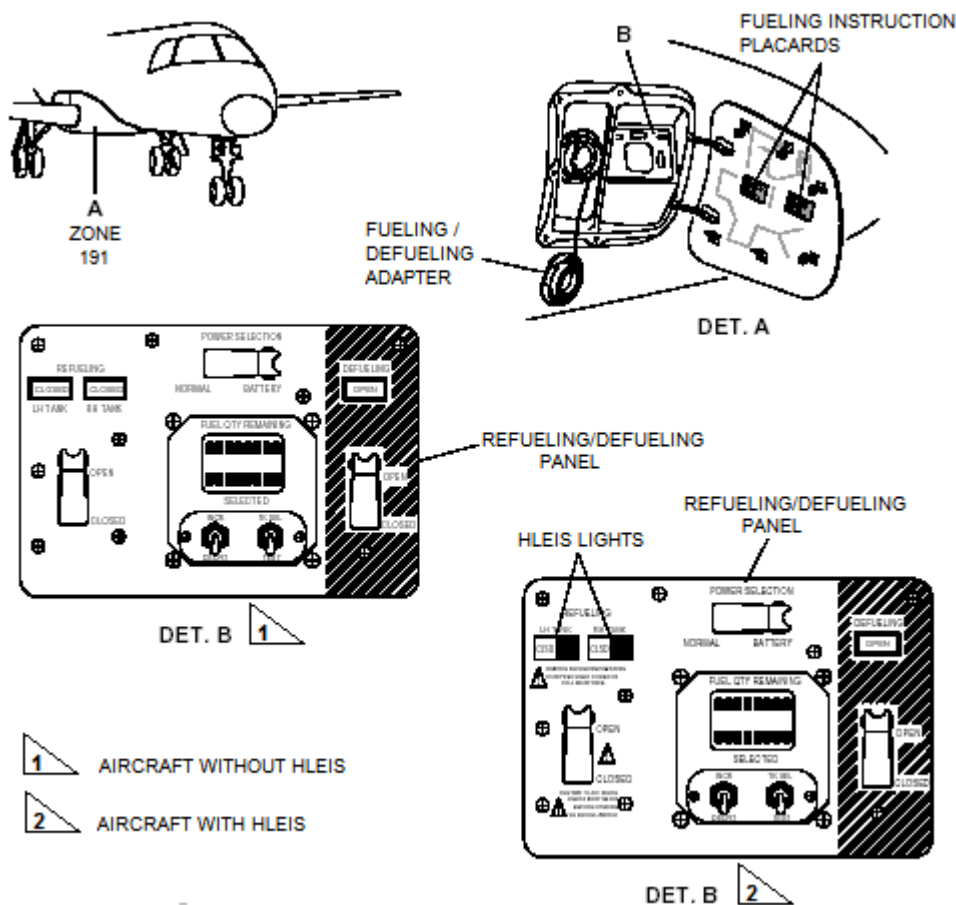

H. PROCEDURES – GRAVITY REFUELING

1. Ensure that the nose landing gear wheels are properly chocked. Refer to FSPM 02-03.
2. The amount of fuel service required will be provided by the Envoy Station Operations office. Once this amount has been obtained it will be necessary to convert the pound amount to gallons. Do this by dividing the pound amount by 6.7. For example, if the aircraft is to be fueled to 8000 lbs. divide 8000 by 6.7:

$$8000 \div 6.7 = 1,194 \text{ Gal.}$$

Then split that amount in half and this will be the amount that will be fueled into each wing (unless the pilot requests that the fuel be distributed differently).

3. Statically bond the aircraft.

NOTE

Make all bonding connections between the fuel source, aircraft and fuel nozzle [Ref. FSPM 02-04 and any local regulatory authority requirements].

4. Place servicing mats over wing skins, ensure that wing skins are dry and mats are dry and uncontaminated. Mat should cover an area 12 inches past the fueling opening.

CAUTION

Ensure that the servicing mat is free from contamination, (metal shavings, etc.) when it is installed over refueling area.

5. Open filler caps 541FT for the LH tank and 641FT for the RH tank. See Figure FSPM 05-00D ([p.7](#)).

CAUTION

Do not use screwdrivers, etc. to remove the caps. This results in damage to the caps. If the use of a tool is absolutely necessary, a tool made of non-metallic material such as wood or plexiglas is authorized.

6. Insert fuel nozzle ensuring not to damage the filter inside the wing structure.

WARNING

Ensure that maximum fuel imbalance limitations are observed. Do not exceed 800 lb. (362.88 kg) imbalance between the main tanks when refueling, as the aircraft may move/shift and cause injuries to personnel and/or damage to equipment.

7. Start the fueling. At the same time, monitor the fuel level in the tank.
 - a) The two wing tanks may be refueled at the same time or first one and then the other.
 - b) Make sure that there is no fuel imbalance when the procedure is completed.
8. When fueling is complete, remove the fueling nozzle and reinstall the overwing refueling caps 541FT for the LH tank and 641FT for the RH tank. Ensure the caps have a positive lock.
9. Remove the servicing mat.
10. Remove bonding cable.

CONTINUED ON FOLLOWING PAGE

FIGURE FSPM 05-00D: GRAVITY REFUELING

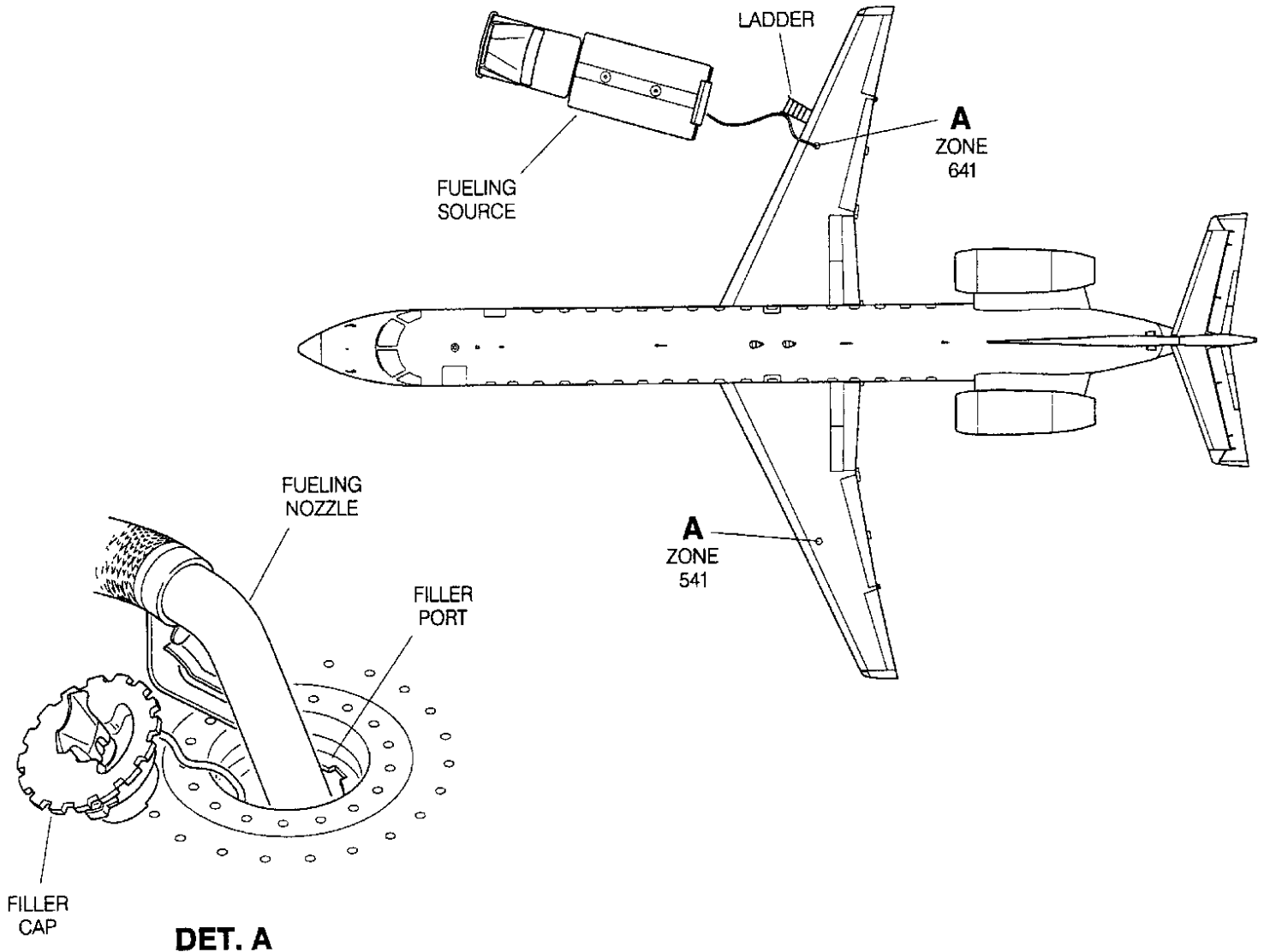

WARNING

Observe all necessary safety precautions and practices during any fueling operation. Aircraft and fueling facility must be correctly bonded before any fueling operation to prevent fire or explosion due to the discharge of static electricity.

I. GENERAL PROCEDURES – DEFUELING

WARNING

If defueling is to be accomplished, secure permission from a flight crew member. Defueling without guidance from Envoy Air Inc. personnel is prohibited.

J. PROCEDURES – PRESSURE DEFUELING

1. Statically bond the aircraft.

NOTE

Make all bonding connections between the fuel source, aircraft and fuel nozzle [Ref. FSPM 02-04 and any local regulatory authority requirements].

2. Energize the aircraft with the external DC power supply.

NOTE

An external DC power supply must be used.

3. Open access door 191BR.
4. Make sure that the DEFUELING light is OFF.
5. Remove the protection cover from the pressure refueling adapter.
6. Connect the fuel nozzle to the pressure refueling adapter.

WARNING

Ensure that maximum fuel imbalance limitations are observed. Do not exceed 800 lb. (362.88 kg) imbalance between the main tanks when defueling, as the aircraft may move/shift and cause injuries to personnel and/or damage to equipment.

7. Set the DEFUELING switch to the OPEN position and make sure that the DEFUELING light comes ON (OPEN).

WARNING

Suction defueling must be coordinated with the flight crew to prevent damage to internal aircraft parts.

8. To prevent collapse of internal fuel lines, coordinate with the flight crew or maintenance personnel to set internal aircraft fuel pumps and XFEED switch on the cockpit overhead fuel control panel as applicable.

WARNING

Suction greater than -4psig may cause damage to internal aircraft components. Monitor fuel vehicle pump pressure at all times.

9. Set the aircraft PUMP PWR switches on the overhead panel to the ON position, then apply suction (4 psig MAX) to the nozzle.
10. When only the necessary fuel quantity remains, set the DEFUELING switch to the CLOSED position and make sure that its light goes OFF.

CAUTION

To prevent damage, do not permit the dry operation of the aircraft fuel pumps during the defueling operation.

11. Set the PUMP PWR and XFEED switches to the OFF position.
12. Disconnect the fuel nozzle from the pressure refueling adapter.
13. Install the protection cover to the pressure refueling adapter.
14. De-energize the aircraft.

WARNING

Make sure that all switch guards are in the closed position on the fuel panel.

15. Close access door.
16. Remove the bonding cable from the aircraft.

K. PROCEDURES – GRAVITY DEFUELING

1. The Embraer aircraft is designed to be gravity defueled although it requires specialized equipment. For locations with proper equipment to gravity defuel, reference Embraer Aircraft Maintenance Manual 12-11-02-600-802-A for complete instructions.

WARNING

Ensure that maximum fuel imbalance limitations are observed. Do not exceed 800 lb. (362.88 kg) imbalance between the main tanks when defueling, as the aircraft may move/shift and cause injuries to personnel and/or damage to equipment.

END

ERJ-175 FUEL SERVICING

CONTENTS

05-03.A	General	1
05-03.B	Fuel Specifications	1
05-03.C	Fuel Capacities	1
05-03.D	Fueling Precautions	2
05-03.E	Bonding Points	3
05-03.F	General Procedures – Fueling	4
05-03.G	Procedures – Pressure Refueling	4
05-03.H	Procedures – Gravity Refueling	7
05-03.I	General Procedures – Defueling	10
05-03.J	Procedures – Pressure Defueling	10

TABLES

Table FSPM 05-03.a	Approved Fuels	1
Table FSPM 05-03.b	Fuel Tank Capacities	1

A. GENERAL

- Fueling can be accomplished by pressure or gravity method utilizing external or battery power.
- When a problem is encountered during fuel servicing, it must be investigated and corrected. These may include spills/leaks, valve or indication problems, malfunctioning equipment, damage, etc. For example, fuel spillage through an aircraft fuel tank vent during pressure refueling may indicate a malfunction of a tank valve or over-pressurization of a tank due to malfunction of fueling equipment.
- Observe “Precautions Required for Aircraft Servicing” as contained in FSPM 02-02.
- Access to the fuel control panel and pressure fueling adapter are through the access door 616HB. See Figure FSPM 05-03C, Detail A.

B. FUEL SPECIFICATIONS

- Approved Fuels include the following:

Table FSPM 0503.a: Approved Fuels

GROUP	SPECIFICATION	COMMERCIAL PRODUCT	SUPPLIER / MANUFACTURER
Engine Fuel	ASTM D1655	JET A, JET A-1	Local Supplier
	MIL-T83133A	JP8	Local Supplier

NOTE

If using Fuel-System Icing Inhibitors (FSII), the following may be used: Di-Ethylene Glycol Monomethyl Ether (Di-EGME), which meets the requirements of MIL-I-85470A. Follow the fluid manufacturer’s specifications for the additive proportions.

C. FUEL CAPACITIES

- The following table shows usable fuel tank capacities. Fuel weight is fuel with an API density of 42.7 at 60° F; weight will vary with fuel density.

NOTE

The following information is applicable to ERJ-175.

Table FSPM 0503.b: Fuel Tank Capacities

LOCATIONS	U.S. GALLONS	LITERS	POUNDS
Left Wing	1535.5	5812.5	10392.5
Right Wing	1535.5	5812.5	10392.5
Total	3071	11725	20785

D. FUELING PRECAUTIONS

1. Observe the precautions in Figure FSPM 05-03A during fueling/defueling.

FIGURE FSPM 05-03A

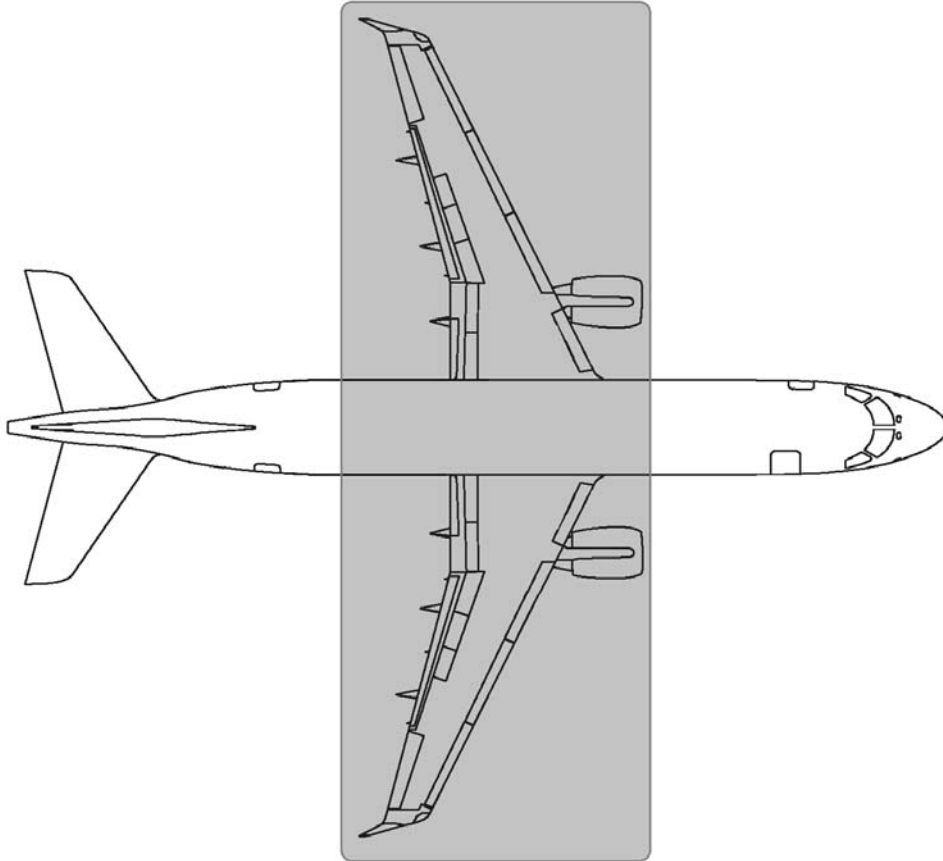

Keep vehicles and equipment free from the shaded area during pressure refueling operation.

CONTINUED ON FOLLOWING PAGE

E. BONDING POINTS

1. Bonding points are shown in Figure FSPM 05-03B.

FIGURE FSPM 05-03B: SERVICING BONDING POINTS

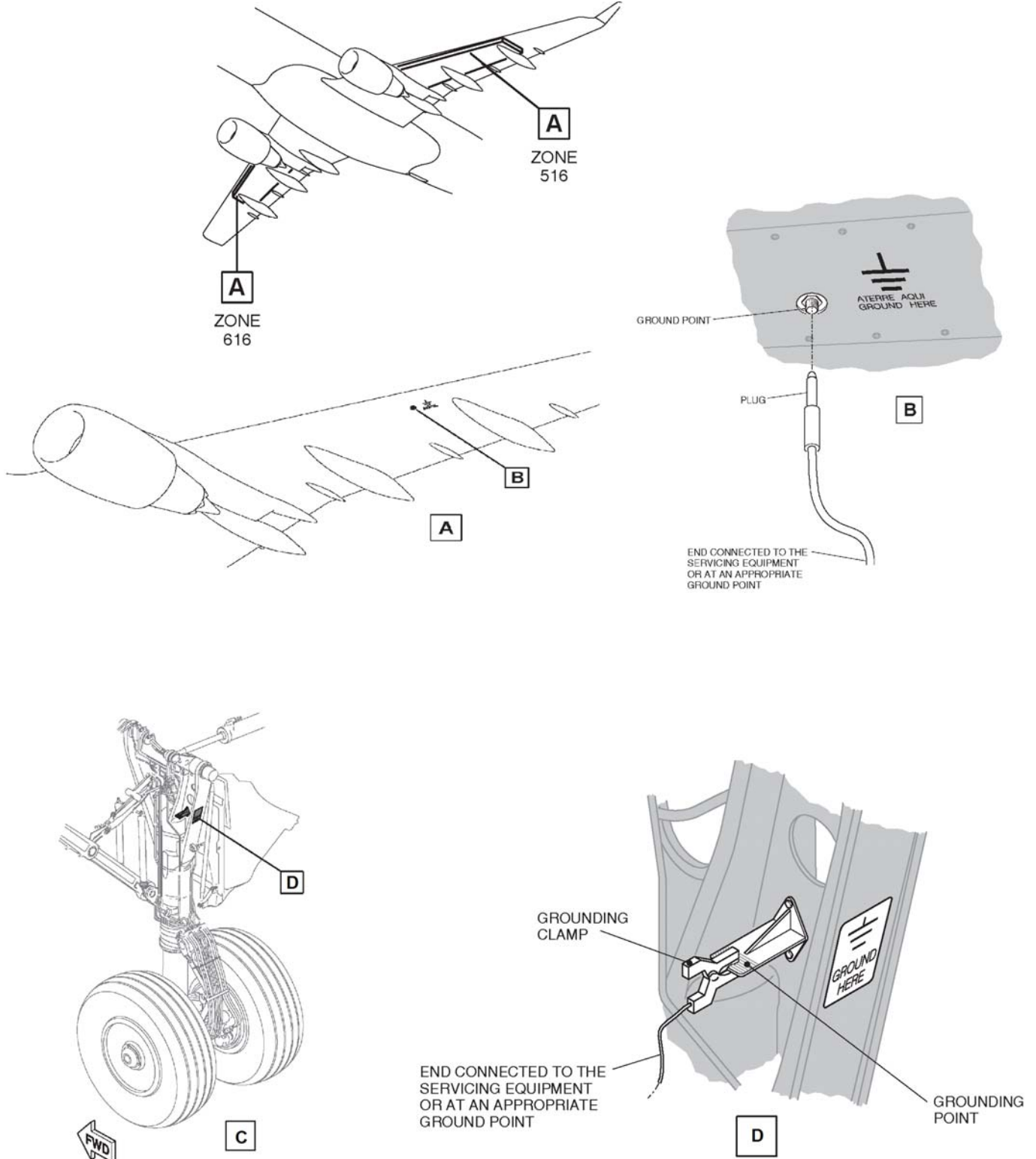

CAUTION

During all fueling operations, ensure aircraft is electrically bonded.

F. GENERAL PROCEDURES – FUELING

1. Envoy considers all aircraft ground time (with or without passengers on board) a fueling/defueling period.
2. The fueler is responsible for the fueling operation. The fueler's employer is responsible for ensuring that all employees who fuel Envoy aircraft:
 - a) Have been properly trained.
 - b) Have a clear understanding of all required communication procedures and methods.
 - c) Provides notification to the flight crew or other qualified personnel when a hazardous condition or situation has been determined to exist.
 - d) Have the ability to execute such procedures in an expeditious manner should a dangerous situation develop.
3. A suitable method of notification to the flight crew or other qualified persons may include use of the aircraft inter-communication system, direct person-to-person contact or other methods that ensure direct and timely communication.
4. If a fuel spill occurs at any time, use the procedures in FSPM 02-05.
5. Station Personnel will coordinate with the Flight Crew about the decision to deplane.
6. Flight Attendants will be stationed in the aircraft cabin as outlined in the Envoy Inflight Procedures Manual.
7. When fueling with passengers on board, the jetbridge or passenger loading stairs must be positioned at an entry door of the airplane and the door will remain open.
8. Pilots are not required to be present during fueling with or without passengers on-board, however, if present must ensure ability to communicate is maintained by any suitable means between the fuel vendor and qualified on-board personnel.
9. Fueling equipment shall not be positioned to obstruct aircraft emergency exit routes (including evacuation chutes) with or without passengers on board.
10. Smoking is not permitted on the aircraft or on the ramp at any time.

G. PROCEDURES – PRESSURE REFUELING

CAUTION

If the Pressure Refuel/Defuel system or the Fuel Quantity gages on the refuel panel are on MEL, Gravity/Overwing refueling must be accomplished.

1. Ensure that the nose landing gear wheels are properly chocked. Refer to FSPM 02-03.
2. Statically bond the aircraft.

NOTE

Make all bonding connections between the fuel source, aircraft, and fuel nozzle [Ref. FSPM 02-04 and any local regulatory authority requirements].

3. Energize the aircraft with external AC Power Supply.

NOTE

If the external AC Power Supply is not available, set the power selection switch to the battery position, on the refueling panel.

4. Open access door 616HB. See Figure FSPM 05-03C ([p 7](#)).

CAUTION

Ensure the NACA air intake is free from blockage. If this caution is ignored, damage to the aircraft can occur.

5. Perform the fuel-tank pressure refueling in the auto mode as follows:
 - a) REFUELING switch is in the CLOSE position.
 - b) REFUELING lights for the LH and RH tanks are OFF.
 - c) DEFUELING light is OFF.
 - d) REFUEL SELECTION switch in the AUTO position.
 - e) Set the repeater indicator (4) to the necessary fuel quantity.

- f) Remove the cap (2) from the pressure refueling/defueling adapter assembly (1).
- g) Inspect refueling adapter for missing or damaged lugs and signs of cracks or contamination.

WARNING

Ensure the refueling adapter is in good condition. A bad connection of the fuel nozzle may cause fuel spillage, fire, injury to persons and damage to the equipment.

- h) Connect the fuel nozzle to the pressure refueling/defueling adapter assembly (1).
- i) Open the valve handle on the fuel nozzle.

CAUTION

During the pressure refueling procedure, ensure the refueling pressure is between 35 and 50 psi. Pressure above the specified limits may cause damage to equipment and injuries to personnel. Pressure below the specified limits may cause unsatisfactory operation of the refueling components.

- j) Pressurize the fuel system from 241.32 - 344.74 kPa (35 - 50 psig).
- k) Ensure the REFUELING lights related to the LH and RH tanks are ON (CLOSED or CLSD, as applicable) and no fuel flows.
- l) Set the REFUELING switch to the OPEN position and ensure the REFUELING lights related to LH and RH tanks are OFF.

CAUTION

Stop the refueling operation if blackout occurs or any message displays on the refuel panel. Fuel leakage can occur and cause damage to the aircraft if this precaution is disobeyed.

- m) If the STOP R OVER, STOP L OVER, or STOP L/R OVER message displays on the repeater indicator (4), immediately remove the fuel pressure coming from the refueling source and stop the refueling procedure.

CAUTION

During the refueling procedure, ensure there is no fuel overflow. Overfilling causes fuel overflow through the NACA air inlet and pressure relief valve. If an overflow occurs and the pressure relief valve does not open, damage to the aircraft structure can occur.

- n) Upon necessary fuel quantity, ensure the LH and RH refueling indication lights (3) are on and fuel flow stops.

NOTE

If fuel overflow occurs, stop the refueling procedure immediately and do AMM MPP 05-50-21/600.

- o) Set the REFUELING switch to the CLOSED position.
- p) Close the valve handle on the fuel nozzle.
- q) Remove the fuel nozzle from the pressure fueling adapter.
- r) Inspect the refueling/defueling adapter assembly (1) for indication of leakage.
- s) Install the protection cover to the pressure refueling adapter.

CAUTION

Ensure the NACA air intake is free from blockage. If this caution is ignored, damage to the aircraft can occur.

- 6. Perform fuel-tank pressure refueling in the manual mode as follows:

- a) LH and RH refueling indication lights (3) are OFF.
- b) Defueling indication light (5) is OFF.
- c) REFUEL SELECTION switch to the MANUAL position.
- d) Remove the cap (2) from the pressure refueling/defueling adapter assembly (1).
- e) Inspect refueling adapter for missing or damaged lugs and signs of cracks or contamination.

WARNING

Ensure the refueling adapter is in good condition. A bad connection of the fuel nozzle may cause fuel spillage, fire, injury to persons and damage to the equipment.

- f) Connect the fuel nozzle to the pressure refueling/defueling adapter assembly (1).

- g) Open the valve handle on the fuel nozzle.
 - h) Pressurize the fuel system with 241.32 - 344.74 kPa (35 - 50 psig).
 - i) Ensure the LH and RH refueling indication lights (3) are on and there is no fuel flow.
 - j) Set the REFUELING switch to OPEN position and ensure the LH and RH refueling indication lights (3) are off.
 - k) When the required fuel quantity has been delivered, set the REFUELING switch to the CLOSED position.
 - l) Ensure the LH and RH refueling indication lights (3) are on and fuel flow stops.
 - m) Close the valve handle on the fuel nozzle.
 - n) Disconnect the fuel nozzle from the pressure refueling/defueling adapter assembly (1).
 - o) Inspect the refueling/defueling adapter assembly (1) for indication of leakage.
 - p) Install the cap (2) to the pressure refueling/defueling adapter assembly (1).
7. Disconnect the external AC power supply from the aircraft.

NOTE

If the POWER SELECTION switch at the BATTERY position was used, set it back to the NORMAL position and close the switch guard.

- 8. Remove the bonding cable from the aircraft.
- 9. Close access door 616HB.

CONTINUED ON FOLLOWING PAGE

Fueling and Servicing Procedures Manual

FIGURE FSPM 05-03C: PRESSURE REFUELING

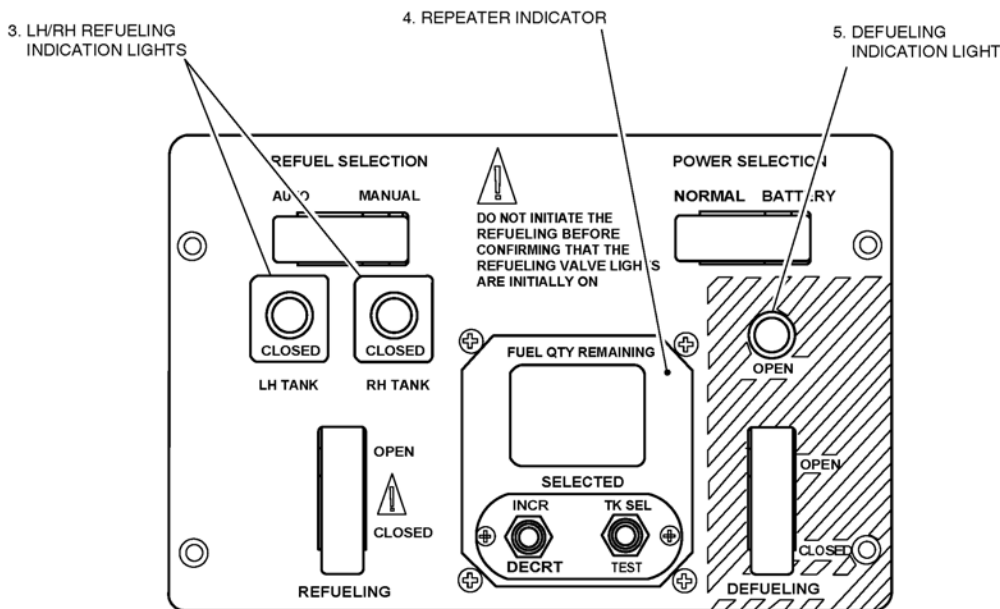
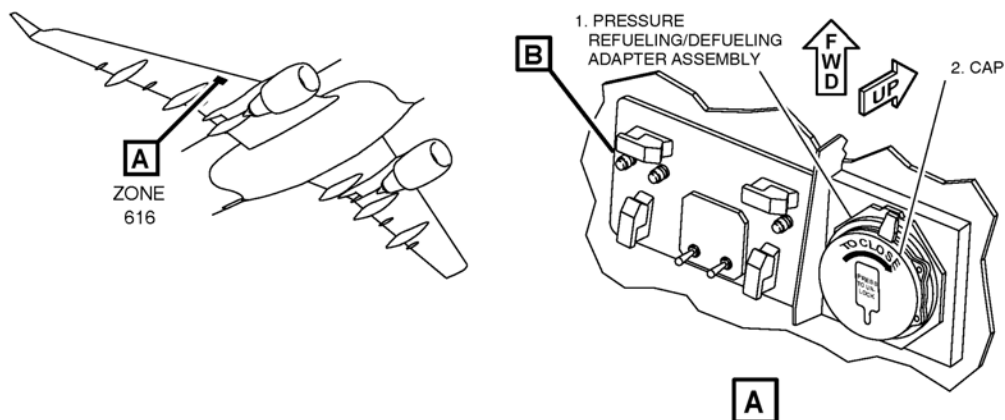

REFUELING/DEFUELING CONTROL PANEL

B

H. PROCEDURES – GRAVITY REFUELING

1. Ensure that the nose landing gear wheels are properly chocked. Refer to FSPM 02-03.
2. The amount of fuel service required will be provided by the Envoy Station Operations office. After obtaining amount, convert to gallons by dividing the pound amount by 6.7.
For example, if the aircraft requires 8000 pounds of fuel, divide 8000 by 6.7:

$$8000 / 6.7 = 1,194 \text{ Gal.}$$

Divide amount evenly into each wing (unless the pilot requests fuel be distributed differently).

3. Statically bond the aircraft.

NOTE

Make all bonding connections between the fuel source, aircraft and fuel nozzle [Ref. FSPM 02-04 and any local regulatory authority requirements].

- Place servicing mats over wing skins, ensure that wing skins are dry and mats are dry and uncontaminated. Mat should cover an area 12 inches past the fueling opening.

CAUTION

Ensure the servicing mat is free from contamination, (metal shavings, etc.) when installed over refueling area.

- Energize the aircraft with external AC Power Supply.

NOTE

If the external AC Power Supply is not available, set the power selection switch to the battery position, on the refueling panel. If the aircraft power supply (battery or external power) is not available, use magnetic level indicators for fuel quantity measure.

- Open access door 616HB. See Figure FSPM 05-03C ([p 7](#)).
- For the LH fuel tank, open the LH gravity-fill cap (1). See Figure FSPM 05-03D.
- For the RH fuel tank, open the RH gravity-fill cap (1). See Figure FSPM 05-03D.

CAUTION

Ensure the NACA air intake is free from blockage. If this caution is ignored, damage to the aircraft can occur.

WARNING

Ensure maximum fuel imbalance limitations are observed. Do not exceed 794 lb. (360.15 kg) imbalance between the main tanks when refueling, as the aircraft may move/shift and cause injuries to personnel and/or damage to equipment.

- Start the fueling. At the same time, monitor the fuel level in the tank.
 - The two wing tanks may be refueled at the same time or first one and then the other.
 - Make sure that there is no fuel imbalance when the procedure is completed.
- When fueling is complete, remove the fueling nozzle and ensure the cap(s) have a positive lock.
- De-energize the aircraft.

NOTE

If the POWER SELECTION switch at the BATTERY position was used, set it back to the NORMAL position and close the switch guard.

- Close access door 616HB.
- Remove the servicing mat.
- Remove bonding cable.

CONTINUED ON FOLLOWING PAGE

FIGURE FSPM 05-03D: GRAVITY REFUELING

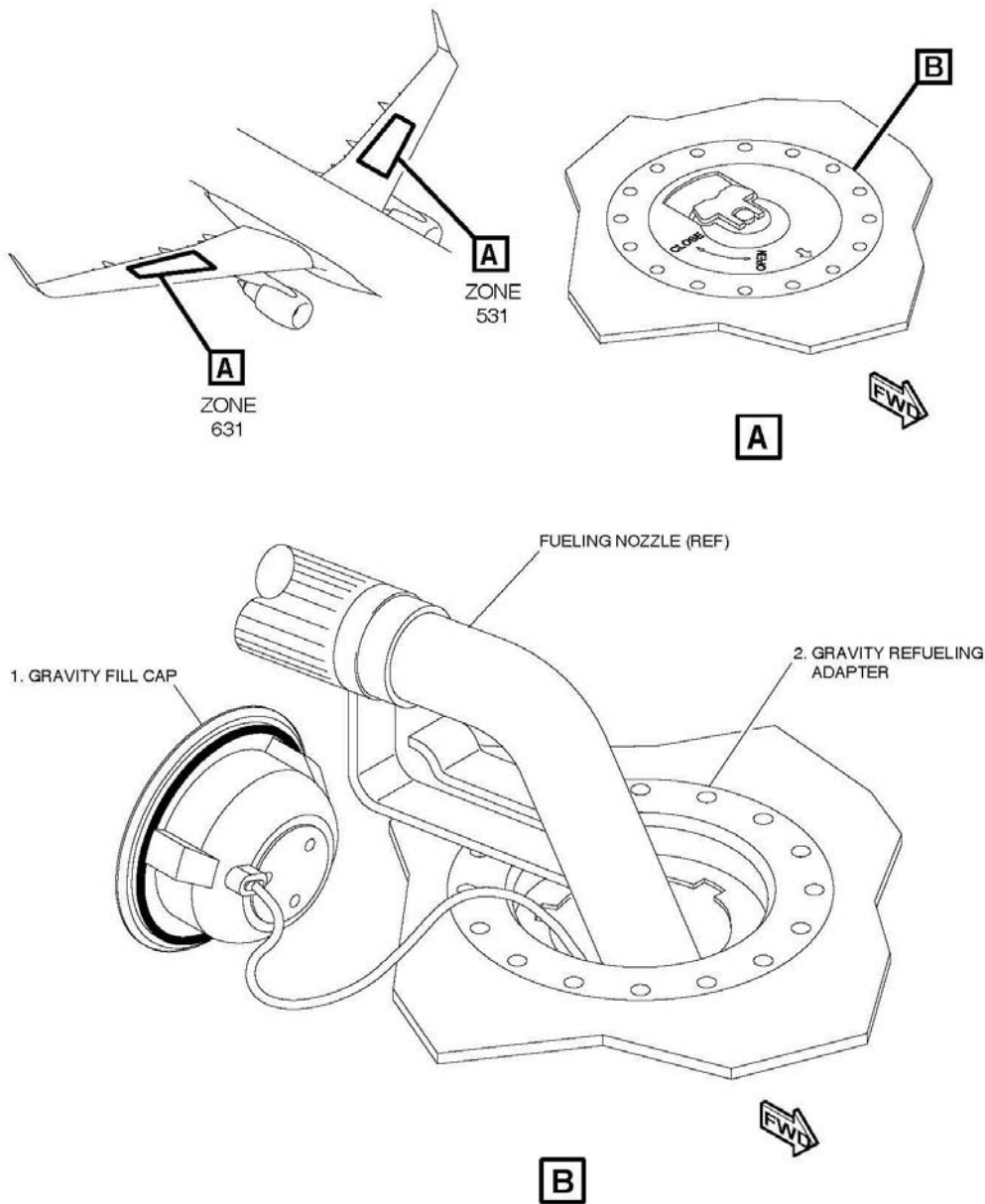

WARNING

Observe all necessary safety precautions and practices during any fueling operation. Aircraft and fueling facility must be correctly bonded before any fueling operation to prevent fire or explosion due to the discharge of static electricity.

CONTINUED ON FOLLOWING PAGE

I. GENERAL PROCEDURES – DEFUELING

CAUTION

If defueling is to be accomplished, secure permission from a flight crew member. Defueling without guidance from Envoy Air Inc. personnel is prohibited.

J. PROCEDURES – PRESSURE DEFUELING

WARNING

Ensure the Refueling Adapter is in good condition. A bad connection of the fuel nozzle may cause fuel spillage, fire, injury to persons and damage to equipment.

1. Ensure aircraft and fuel system are safe for maintenance.
2. Statically bond the aircraft.

NOTE

Make all bonding connections between the fuel source, aircraft and fuel nozzle [Ref. FSPM 02-04 and any local regulatory authority requirements].

3. Open access door 616HB.
4. Energize the aircraft with the external AC power supply.

CAUTION

Ensure the NACA air intake is free from blockage. If this caution is ignored, damage to the aircraft can occur.

5. Ensure the DEFUELING light is OFF.
6. Remove the protection cover from the pressure refueling adapter.
7. Connect the fuel nozzle to the pressure refueling/defueling adapter.
8. Open valve handle on fuel nozzle.
9. Set the DEFUELING switch to the OPEN position and ensure the DEFUELING light is ON (OPEN).

WARNING

Suction defueling must be coordinated with the flight crew to prevent damage to internal aircraft parts.

10. On the FUEL CONTROL PANEL, set the XFEED switch as applicable (accomplished by Flight Crew):
 - a) To defuel two tanks, set switch to LOW 2 position or LOW 1 position.
 - b) To defuel the LH tank, set switch to OFF position.
 - c) To defuel the RH tank, set switch to LOW 1 position.

CAUTION

When defueling the tank, stop when indication displays 0 (zero). A small quantity of fuel remains in the tank preventing damage to the fuel pump. Damage to the fuel pump will occur if it operates with no fuel (dry operation). To prevent damage, do not permit the dry operation of the aircraft fuel pumps during the defueling operation.

CAUTION

Suction greater than 4psig (0.3 bar) may damage internal aircraft components. Monitor fuel vehicle pump pressure at all times.

NOTE

Applying suction to the fuel nozzle with the AC PUMP, less time is required for the pressure defueling procedure.

11. Apply suction to the fuel nozzle and/or set the AC PUMP switches on the FUEL control panel, as applicable:
 - a) To defuel two tanks, set AC PUMP 1 and AC PUMP 2 switches to ON position.
 - b) To defuel the LH tank, set AC PUMP 1 switch to ON position
 - c) To defuel the RH tank, set AC PUMP 2 switch to ON position
12. Upon completing the defueling operation, set DEFUELING switch to CLOSED position and ensure the defueling indicator light is off.

13. Set XFEED switch to OFF position (accomplished by Flight Crew).
14. Set AC PUMP 1 and AC PUMP 2 switches to AUTO position.
15. Close valve handle on the fuel nozzle.
16. Disconnect fuel nozzle from the pressure refueling/defueling adapter assembly.
17. Install cap to pressure refueling/defueling adapter assembly
18. Set PUMP PWR and XFEED switches to OFF position.
19. De-energize the aircraft.
20. Close access door 616HB.
21. Remove the bonding cable from the aircraft.

END

Fueling and Servicing Procedures Manual

FORMS

CONTENTS

06-00.A	General	1
06-00.B	Requisitioning	1
06-00.C	Revisions	1
06-00.D	Form Numbering	1

TABLES

Table FSPM 06-00.a	Form Numbering	1
--------------------	----------------	---

A. GENERAL

- Forms are designed to provide consistent means of recording and transferring information. Forms with little or no usage are to be brought to the attention of the department head.
- Any or all of these forms can be produced for vendors' use. Vendors are not required to use the forms indicated, however the vendor must document the required information/checks in an equivalent manner (i.e. equal to ATA 103 requirements).
- All forms must be available for the Company to review.

B. REQUISITIONING

- Management is responsible for:
 - Ensuring an adequate supply of forms is available.
 - Producing the form by:
 - Copying from the manual.
 - Printing via computer at the [Tech Pubs website](#).
 - Personnel who reproduce forms, as stated above, are responsible for ensuring that the correct version of the form is utilized.

C. REVISIONS

- Revisions to forms may be submitted and processed:
 - By vendors, in accordance with the instructions in Section 01-03 of this manual [Ref. FSPM 01-03].
 - By Company employees, via Request For Service (RFS) [Ref. GPM 04-09].

D. FORM NUMBERING

- To assist in locating the proper form, the forms are normally identified in the following manner (using '0307' as an example):

Table FSPM 0600.a: Form Numbering

AE	FSPM	0307	.1
AIRCRAFT EQUIPMENT	FUELING AND SERVICING PROCEDURES MANUAL DESIGNATOR	CHAPTER/SECTION OF FSPM DESCRIBING FORM	NUMERICAL SEQUENCE (IF APPLICABLE) – WHEN MORE THAN ONE FORM IS DESCRIBED IN THE SECTION

END

Fueling and Servicing Procedures Manual

FORMS INDEX

CONTENTS

06-01.A	General	1
06-01.B	Numeric Sequence Forms Index	1
06-01.C	Alphabetic Sequence Forms Index	2

TABLES

Table FSPM 06-01.a	Numeric Sequence Forms Index	1
Table FSPM 06-01.b	Alphabetic Sequence Forms Index	2

A. GENERAL

- Forms that appear in this manual are listed below.
- Form titles are listed as they appear on the form.
- The Form Number and Form Title columns contain form numbers and titles sorted in numeric sequence by form number and alphabetic sequence by form title.
- The Form Date column indicates the revision date of the form.
- The Chapter/Section column lists where the form is located.
- Unless otherwise specified in the applicable chapter/section:
 - Previous versions of all completed Company forms are considered valid after a new or revised form is implemented.
 - Current supplies may be used until exhausted.
- "PL" (Printed Locally) in the Source column indicates that forms may be produced by printing via computer from the [Forms website](#).
- Personnel who reproduce forms are responsible for ensuring the correct version of the form is utilized.

B. NUMERIC SEQUENCE FORMS INDEX

Table FSPM 0601.a: Numeric Sequence Forms Index

Form Number	Form Title	Form Date	Chapter/Section	ATA Equivalent
1. 0200	Fuel Vendor Training Record	07 Apr 20	02-00	N/A
2. 0200.1	Designated Trainer Authorization	07 Apr 20	02-00	N/A
3. 0206	Non-Listed Fueling Procedures	01 Oct 19	02-06	N/A
4. 0302	Pipeline Record of Receipt	04 May 10	03-02	103.03
5. 0303	Jet Fuel Storage Facility Transport Truck Record of Receipt	04 May 10	03-03	103.02
6. 0305	Fuel Quality Test Record	03 Nov 09	03-05	103.08
7. 0305.1	Daily Fuel Facility Checklist	03 Nov 09	03-05	103.01B
8. 0305.2	Daily/Monthly Fuel Facility Checklist	03 Nov 09	03-05	103.01A
9. 0305.3	Quarterly/Semi-Annual Fuel Facility Checklist	03 Nov 09	03-05	103.01C
10. 0305.4	Annual Fuel Facility Checklist	03 Nov 09	03-05	103.01D
11. 0307	Daily Fueling Equipment Checklist	03 Nov 09	03-07	103.04A
12. 0307.1	Monthly Fueling Equipment Checklist	03 Nov 09	03-07	103.04B
13. 0307.2	Quarterly/Semi-Annual/Annual Fueling Equipment Checklist	03 Nov 09	03-07	103.04C
14. 0308	Daily Hydrant System Checklist	04 May 10	03-08	103.05A

Fueling and Servicing Procedures Manual

06-01
Page 2 of 2
07 Apr 20

Table FSPM 0601.a: Numeric Sequence Forms Index

Form Number AE-FSPM-	Form Title	Form Date	Chapter/ Section	ATA Equivalent
15. 0308.1	Monthly Hydrant System Checklist	04 May 10	03-08	103.05B
16. 0308.2	Quarterly/Annual Hydrant System Checklist	04 May 10	03-08	103.05C
17. 0314	Fuel Filter Vessel Record	03 Nov 09	03-14	103.06
18. 0317	Storage and Reclamation Tank Inspection and Cleaning Record	04 May 10	03-17	103.07

C. ALPHABETIC SEQUENCE FORMS INDEX

Table FSPM 0601.b: Alphabetic Sequence Forms Index

Form Title	Form Number AE-FSPM-	Source	Chapter/ Section	ATA Equivalent
1. Annual Fuel Facility Checklist	0305.4	PL	03-05	103.01D
2. Daily Aircraft Fueling Equipment Checklist	0307	PL	03-07	103.04A
3. Daily Fuel Facility Checklist	0305.1	PL	03-05	103.01B
4. Daily Hydrant System Checklist	0308	PL	03-08	103.05A
5. Daily/Monthly Fuel Facility Checklist	0305.2	PL	03-05	103.01A
6. Designated Trainer Authorization	0200.1	PL	02-00	N/A
7. Fuel Filter Vessel Record	0314	PL	03-14	103.06
8. Fuel Quality Test Record	0305	PL	03-05	103.08
9. Fuel Vendor Training Record	0200	PL	02-00	N/A
10. Jet Fuel Storage Facility Transport Truck Record of Receipt	0303	PL	03-03	103.02
11. Monthly Fueling Equipment Checklist	0307.1	PL	03-07	103.04B
12. Monthly Hydrant System Checklist	0308.1	PL	03-08	103.05B
13. Non-Listed Fueling Procedures	0206	PL	02-06	N/A
14. Pipeline Record of Receipt	0302	PL	03-02	103.03
15. Quarterly/Annual Hydrant System Checklist	0308.2	PL	03-08	103.05C
16. Quarterly/Semi-Annual Fuel Facility Checklist	0305.3	PL	03-05	103.01C
17. Quarterly/Semi-Annual/Annual Fueling Equipment Checklist	0307.2	PL	03-07	103.04C
18. Storage and Reclamation Tank Inspection and Cleaning Record	0317	PL	03-17	103.07

END